

FXK = Heating recovery unit

INDOOR FAN

External static pressure (Pa)

Table 6.11

Air flow	100	125	150	175	200	225	250	275	300	325	350	375	400	
	Kit P	RPM	Kit P	RPM	Kit P	RPM	Kit P	RPM	Kit P	RPM	Kit P	RPM	Kit P	RPM
7200	K1 1*1.1 580	K2 1*1.5 613	K2 1*1.5 645	K2 1*1.5 677	K2 1*1.5 708	K3 1*1.5 738	K3 1*1.5 768	K3 1*1.5 797	K4 1*2.2 826	K4 1*2.2 854	K4 1*2.2 881	K5 1*2.2 908	K5 1*2.2 934	
8200	K2 1*1.5 625	K2 1*1.5 655	K2 1*1.5 684	K2 1*1.5 713	K6 1*2.2 741	K6 1*2.2 769	K6 1*2.2 796	K4 1*2.2 823	K4 1*2.2 849	K4 1*2.2 875	K4 1*2.2 901	K7 1*3.0 926	K7 1*3.0 951	
9000	K2 1*1.5 664	K9 1*2.2 691	K9 1*2.2 718	K6 1*2.2 745	K6 1*2.2 771	K6 1*2.2 797	K4 1*2.2 823	K4 1*2.2 848	K8 1*3.0 873	K8 1*3.0 897	K8 1*3.0 921	K7 1*3.0 945	K7 1*3.0 969	
9400	K9 1*2.2 684	K9 1*2.2 710	K6 1*2.2 736	K6 1*2.2 762	K6 1*2.2 787	K4 1*2.2 812	K8 1*3.0 837	K8 1*3.0 861	K8 1*3.0 886	K8 1*3.0 909	K7 1*3.0 933	K7 1*3.0 956	K7 1*3.0 979	
9900	K9 1*2.2 709	K6 1*2.2 734	K6 1*2.2 759	K6 1*2.2 784	K8 1*3.0 808	K8 1*3.0 832	K8 1*3.0 856	K8 1*3.0 879	K8 1*3.0 903	K7 1*3.0 926	K7 1*3.0 948	K10 1*4.0 971	K10 1*4.0 993	

FX 55

Table 6.12

Air flow	100	125	150	175	200	225	250	275	300	325	350	375	400	
	Kit P	RPM	Kit P	RPM	Kit P	RPM	Kit P	RPM	Kit P	RPM	Kit P	RPM	Kit P	RPM
8600	No Kit	K1 1*1.5 504	K1 1*1.5 536	K1 1*1.5 566	K2 1*1.5 596	K2 1*1.5 624	K2 1*1.5 652	K3 1*2.2 678	K3 1*2.2 704	K4 1*2.2 729	K4 1*2.2 753	K4 1*2.2 777	K4 1*2.2 800	
9600	K1 1*1.5 496	K1 1*1.5 527	K1 1*1.5 556	K2 1*1.5 584	K2 1*1.5 612	K7 1*2.2 639	K3 1*2.2 666	K3 1*2.2 691	K3 1*2.2 716	K4 1*2.2 740	K4 1*2.2 764	K5 1*3.0 787	K5 1*3.0 809	
10800	K1 1*1.5 529	K1 1*1.5 557	K7 1*2.2 584	K7 1*2.2 610	K7 1*2.2 636	K3 1*2.2 661	K3 1*2.2 686	K8 1*3.0 710	K8 1*3.0 734	K5 1*3.0 757	K5 1*3.0 779	K5 1*3.0 801	K5 1*3.0 823	
11600	K7 1*2.2 553	K7 1*2.2 578	K7 1*2.2 604	K7 1*2.2 629	K3 1*2.2 653	K8 1*3.0 677	K8 1*3.0 701	K8 1*3.0 724	K5 1*3.0 747	K5 1*3.0 769	K5 1*3.0 791	K9 1*4.0 813	K11 1*4.0 834	
12200	K7 1*2.2 571	K7 1*2.2 595	K7 1*2.2 620	K7 1*2.2 644	K8 1*3.0 667	K8 1*3.0 691	K8 1*3.0 713	K8 1*3.0 736	K5 1*3.0 758	K9 1*4.0 780	K9 1*4.0 801	K9 1*4.0 822	K11 1*4.0 843	

FX 70

Table 6.13

Air flow	100	125	150	175	200	225	250	275	300	325	350	375	400	
	Kit P	RPM	Kit P	RPM	Kit P	RPM	Kit P	RPM	Kit P	RPM	Kit P	RPM	Kit P	RPM
10800	K1 1*2.2 512	K1 1*2.2 540	K1 1*2.2 567	K2 1*2.2 594	K2 1*2.2 620	K2 1*2.2 645	K3 1*3.0 670	K4 1*3.0 695	K4 1*3.0 719	K5 1*3.0 742	K5 1*3.0 765	K5 1*3.0 788	K5 1*3.0 810	
12300	K1 1*2.2 554	K1 1*2.2 579	K2 1*2.2 603	K2 1*2.2 627	K3 1*3.0 651	K4 1*3.0 674	K4 1*3.0 697	K4 1*3.0 720	K5 1*3.0 742	K5 1*3.0 764	K6 1*4.0 786	K6 1*4.0 807	K6 1*4.0 828	
13500	K2 1*2.2 590	K3 1*3.0 612	K3 1*3.0 635	K3 1*3.0 657	K4 1*3.0 679	K4 1*3.0 701	K7 1*4.0 722	K7 1*4.0 743	K6 1*4.0 764	K6 1*4.0 785	K6 1*4.0 806	K6 1*4.0 826	K6 1*4.0 846	
14400	K3 1*3.0 617	K3 1*3.0 638	K4 1*3.0 660	K4 1*3.0 681	K7 1*4.0 701	K7 1*4.0 722	K7 1*4.0 742	K6 1*4.0 763	K6 1*4.0 783	K6 1*4.0 803	K9 1*5.5 822	K8 1*5.5 841	K8 1*5.5 861	
15300	K3 1*3.0 645	K7 1*4.0 665	K7 1*4.0 685	K7 1*4.0 705	K7 1*4.0 725	K6 1*4.0 745	K6 1*4.0 764	K9 1*5.5 783	K9 1*5.5 802	K9 1*5.5 821	K8 1*5.5 840	K8 1*5.5 859	K8 1*5.5 877	

FX 85

Table 6.14

Air flow	100	125	150	175	200	225	250	275	300	325	350	375	400	
	Kit P	RPM	Kit P	RPM	Kit P	RPM	Kit P	RPM	Kit P	RPM	Kit P	RPM	Kit P	RPM
13700	K1 1*3.0 595	K1 1*3.0 618	K1 1*3.0 640	K1 1*3.0 662	K2 1*4.0 683	K2 1*4.0 705	K2 1*4.0 726	K3 1*4.0 747	K3 1*4.0 768	K3 1*4.0 788	K3 1*4.0 809	K3 1*4.0 829	K4 1*5.5 848	
15500	K2 1*4.0 651	K2 1*4.0 671	K2 1*4.0 691	K2 1*4.0 710	K2 1*4.0 730	K3 1*4.0 749	K5 1*5.5 769	K5 1*5.5 788	K5 1*5.5 807	K5 1*5.5 825	K4 1*5.5 844	K4 1*5.5 862	K4 1*5.5 880	
17300	K7 1*5.5 709	K5 1*5.5 727	K5 1*5.5 745	K5 1*5.5 763	K5 1*5.5 780	K5 1*5.5 798	K5 1*5.5 815	K5 1*5.5 833	K6 1*7.5 850	K6 1*7.5 867	K6 1*7.5 884	K6 1*7.5 901	K6 1*7.5 918	
17900	K5 1*5.5 729	K5 1*5.5 746	K5 1*5.5 763	K5 1*5.5 781	K5 1*5.5 798	K5 1*5.5 815	K6 1*7.5 832	K6 1*7.5 849	K6 1*7.5 865	K6 1*7.5 882	K6 1*7.5 899	K6 1*7.5 915	K6 1*7.5 931	
18200	K5 1*5.5 739	K5 1*5.5 756	K5 1*5.5 773	K5 1*5.5 790	K5 1*5.5 807	K6 1*7.5 823	K6 1*7.5 840	K6 1*7.5 857	K6 1*7.5 873	K6 1*7.5 890	K6 1*7.5 906	K6 1*7.5 922	K6 1*7.5 938	

FX 100

P Fan motor power in kW

FXK = Heating recovery unit

INDOOR FAN

External static pressure (Pa)

Table 6.15

Air flow	100	125	150	175	200	225	250	275	300	325	350	375	400
	Kit P RPM	Kit P RPM	Kit P RPM	Kit P RPM	Kit P RPM	Kit P RPM	Kit P RPM	Kit P RPM	Kit P RPM	Kit P RPM	Kit P RPM	Kit P RPM	Kit P RPM
15500	K1 2*1.1 531	K2 2*1.5 562	K2 2*1.5 593	K2 2*1.5 622	K2 2*1.5 650	K2 2*1.5 677	K3 2*2.2 703	K4 2*2.2 729	K4 2*2.2 753	K4 2*2.2 777	K4 2*2.2 800	K4 2*2.2 823	K4 2*2.2 845
17500	K2 2*1.5 567	K2 2*1.5 596	K2 2*1.5 624	K2 2*1.5 652	K3 2*2.2 678	K3 2*2.2 704	K4 2*2.2 729	K4 2*2.2 753	K4 2*2.2 777	K4 2*2.2 800	K6 2*3.0 822	K5 2*3.0 844	K5 2*3.0 865
19000	K2 2*1.5 596	K2 2*1.5 623	K3 2*2.2 650	K3 2*2.2 676	K3 2*2.2 701	K3 2*2.2 726	K4 2*2.2 750	K6 2*3.0 774	K6 2*3.0 796	K6 2*3.0 819	K5 2*3.0 840	K5 2*3.0 862	K5 2*3.0 882
20500	K3 2*2.2 625	K3 2*2.2 652	K3 2*2.2 677	K3 2*2.2 702	K3 2*2.2 726	K6 2*3.0 750	K6 2*3.0 773	K6 2*3.0 795	K6 2*3.0 817	K5 2*3.0 839	K5 2*3.0 860	K7 2*4.0 881	K7 2*4.0 901
21500	K3 2*2.2 646	K3 2*2.2 671	K3 2*2.2 696	K6 2*3.0 719	K6 2*3.0 743	K6 2*3.0 766	K6 2*3.0 788	K6 2*3.0 810	K5 2*3.0 832	K7 2*4.0 853	K7 2*4.0 874	K7 2*4.0 894	K7 2*4.0 914

FX 110

Table 6.16

Air flow	100	125	150	175	200	225	250	275	300	325	350	375	400
	Kit P RPM	Kit P RPM	Kit P RPM	Kit P RPM	Kit P RPM	Kit P RPM	Kit P RPM	Kit P RPM	Kit P RPM	Kit P RPM	Kit P RPM	Kit P RPM	Kit P RPM
19500	K1 2*2.2 581	K1 2*2.2 608	K1 2*2.2 635	K2 2*2.2 662	K2 2*2.2 687	K2 2*2.2 712	K2 2*2.2 736	K3 2*3.0 760	K3 2*3.0 783	K3 2*3.0 806	K3 2*3.0 828	K3 2*3.0 849	K4 2*4.0 870
22000	K1 2*2.2 628	K2 2*2.2 653	K2 2*2.2 678	K5 2*3.0 702	K5 2*3.0 725	K3 2*3.0 749	K3 2*3.0 771	K3 2*3.0 794	K3 2*3.0 815	K4 2*4.0 837	K4 2*4.0 857	K4 2*4.0 878	K4 2*4.0 898
24000	K5 2*3.0 667	K5 2*3.0 690	K5 2*3.0 713	K5 2*3.0 736	K3 2*3.0 758	K3 2*3.0 780	K6 2*4.0 802	K6 2*4.0 823	K4 2*4.0 843	K4 2*4.0 864	K4 2*4.0 884	K4 2*4.0 904	K7 2*5.5 923
25000	K5 2*3.0 687	K5 2*3.0 710	K5 2*3.0 732	K3 2*3.0 754	K6 2*4.0 775	K6 2*4.0 797	K6 2*4.0 818	K4 2*4.0 838	K4 2*4.0 858	K4 2*4.0 878	K7 2*5.5 898	K7 2*5.5 917	K8 2*5.5 936
25500	K5 2*3.0 697	K5 2*3.0 719	K3 2*3.0 741	K6 2*4.0 763	K6 2*4.0 784	K6 2*4.0 805	K6 2*4.0 826	K4 2*4.0 846	K4 2*4.0 866	K7 2*5.5 886	K7 2*5.5 905	K7 2*5.5 924	K8 2*5.5 943

FX 140

Table 6.17

Air flow	100	125	150	175	200	225	250	275	300	325	350	375	400
	Kit P RPM	Kit P RPM	Kit P RPM	Kit P RPM	Kit P RPM	Kit P RPM	Kit P RPM	Kit P RPM	Kit P RPM	Kit P RPM	Kit P RPM	Kit P RPM	Kit P RPM
24000	K1 2*3.0 652	K1 2*3.0 676	K1 2*3.0 699	K1 2*3.0 722	K1 2*3.0 745	K1 2*3.0 767	K2 2*4.0 788	K2 2*4.0 810	K2 2*4.0 831	K3 2*4.0 851	K3 2*4.0 872	K3 2*4.0 891	K3 2*4.0 911
26000	K1 2*3.0 691	K1 2*3.0 713	K1 2*3.0 735	K2 2*4.0 757	K2 2*4.0 778	K2 2*4.0 799	K2 2*4.0 819	K3 2*4.0 839	K3 2*4.0 859	K4 2*5.5 879	K4 2*5.5 898	K4 2*5.5 917	K5 2*5.5 936
27000	K1 2*3.0 711	K2 2*4.0 732	K2 2*4.0 754	K2 2*4.0 774	K2 2*4.0 795	K2 2*4.0 815	K3 2*4.0 835	K4 2*5.5 855	K4 2*5.5 874	K4 2*5.5 894	K4 2*5.5 912	K5 2*5.5 931	K5 2*5.5 949
28000	K2 2*4.0 731	K2 2*4.0 752	K2 2*4.0 772	K2 2*4.0 792	K2 2*4.0 812	K6 2*5.5 832	K4 2*5.5 852	K4 2*5.5 871	K4 2*5.5 890	K4 2*5.5 909	K4 2*5.5 927	K5 2*5.5 945	K5 2*5.5 963
30000	K2 2*4.0 772	K6 2*5.5 791	K6 2*5.5 810	K6 2*5.5 830	K4 2*5.5 848	K4 2*5.5 867	K4 2*5.5 886	K4 2*5.5 904	K4 2*5.5 922	K5 2*5.5 940	K7 2*7.5 957	K7 2*7.5 975	K7 2*7.5 992

FX 170

P Fan motor power in kW

FXK = Heating recovery unit

OUTDOOR FAN

External static pressure (Pa)

Table 6.18

Air flow	100		125		150		175		200		225		250		275		300		325		350		375		400														
	Kit	P	RPM	Kit	P	RPM	Kit	P	RPM	Kit	P	RPM	Kit	P	RPM	Kit	P	RPM	Kit	P	RPM	Kit	P	RPM	Kit	P	RPM												
5000	K1	1*1.1	791	K1	1*1.1	830	K1	1*1.1	868	K2	1*1.1	905	K2	1*1.1	941	K2	1*1.1	976	K3	1*1.5	1011	K3	1*1.5	1045	K4	1*1.5	1078	K4	1*1.5	1110	K4	1*1.5	1142	K4	1*1.5	1173	K4	1*1.5	1203
5125	K1	1*1.1	803	K1	1*1.1	841	K1	1*1.1	878	K2	1*1.1	915	K2	1*1.1	950	K2	1*1.1	985	K3	1*1.5	1019	K3	1*1.5	1053	K4	1*1.5	1085	K4	1*1.5	1117	K4	1*1.5	1149	K4	1*1.5	1179	K5	1*2.2	1209
5250	K1	1*1.1	815	K1	1*1.1	852	K1	1*1.1	889	K2	1*1.1	925	K2	1*1.1	960	K3	1*1.5	994	K3	1*1.5	1028	K4	1*1.5	1061	K4	1*1.5	1093	K4	1*1.5	1125	K4	1*1.5	1156	K5	1*2.2	1186	K5	1*2.2	1216
5375	K1	1*1.1	827	K1	1*1.1	864	K2	1*1.1	900	K2	1*1.1	935	K2	1*1.1	970	K6	1*1.5	1003	K3	1*1.5	1037	K4	1*1.5	1069	K4	1*1.5	1101	K4	1*1.5	1132	K5	1*2.2	1163	K5	1*2.2	1193	K5	1*2.2	1222
5500	K1	1*1.1	840	K1	1*1.1	876	K2	1*1.1	911	K6	1*1.5	945	K6	1*1.5	979	K3	1*1.5	1013	K3	1*1.5	1045	K4	1*1.5	1078	K4	1*1.5	1109	K5	1*2.2	1140	K5	1*2.2	1170	K5	1*2.2	1200	K5	1*2.2	1229

FX 25

Table 6.19

Air flow	100		125		150		175		200		225		250		275		300		325		350		375		400														
	Kit	P	RPM	Kit	P	RPM	Kit	P	RPM	Kit	P	RPM	Kit	P	RPM	Kit	P	RPM	Kit	P	RPM	Kit	P	RPM	Kit	P	RPM												
6250	K1	1*1.5	881	K1	1*1.5	914	K1	1*1.5	946	K1	1*1.5	977	K2	1*2.2	1009	K2	1*2.2	1040	K3	1*2.2	1070	K3	1*2.2	1100	K3	1*2.2	1130	K4	1*2.2	1159	K4	1*2.2	1187	K4	1*2.2	1216	K4	1*2.2	1244
6375	K1	1*1.5	894	K1	1*1.5	925	K1	1*1.5	957	K2	1*2.2	988	K2	1*2.2	1019	K2	1*2.2	1049	K3	1*2.2	1079	K3	1*2.2	1109	K3	1*2.2	1138	K4	1*2.2	1167	K4	1*2.2	1195	K3	1*2.2	1223	K4	1*2.2	1251
6500	K1	1*1.5	906	K1	1*1.5	937	K2	1*2.2	968	K2	1*2.2	999	K2	1*2.2	1029	K2	1*2.2	1059	K3	1*2.2	1089	K3	1*2.2	1118	K4	1*2.2	1147	K4	1*2.2	1175	K4	1*2.2	1203	K4	1*2.2	1231	K5	1*3.0	1258
6625	K1	1*1.5	919	K2	1*2.2	950	K2	1*2.2	980	K2	1*2.2	1010	K2	1*2.2	1040	K3	1*2.2	1069	K3	1*2.2	1099	K3	1*2.2	1127	K4	1*2.2	1156	K4	1*2.2	1184	K4	1*2.2	1212	K5	1*3.0	1239	K5	1*3.0	1266
6750	K2	1*2.2	932	K2	1*2.2	962	K2	1*2.2	992	K2	1*2.2	1021	K2	1*2.2	1051	K3	1*2.2	1080	K3	1*2.2	1109	K3	1*2.2	1137	K4	1*2.2	1165	K4	1*2.2	1193	K5	1*3.0	1220	K5	1*3.0	1247	K5	1*3.0	1274
6875	K2	1*2.2	944	K2	1*2.2	974	K2	1*2.2	1003	K2	1*2.2	1033	K2	1*2.2	1062	K3	1*2.2	1090	K3	1*2.2	1119	K3	1*2.2	1147	K4	1*2.2	1174	K5	1*3.0	1202	K5	1*3.0	1229	K5	1*3.0	1255	K5	1*3.0	1282

FX 30

Table 6.20

Air flow	100		125		150		175		200		225		250		275		300		325		350		375		400														
	Kit	P	RPM	Kit	P	RPM	Kit	P	RPM	Kit	P	RPM	Kit	P	RPM	Kit	P	RPM	Kit	P	RPM	Kit	P	RPM	Kit	P	RPM												
7500	K1	1*1.1	595	K2	1*1.5	627	K2	1*1.5	658	K2	1*1.5	689	K2	1*1.5	719	K3	1*1.5	749	K3	1*1.5	778	K4	1*2.2	806	K5	1*2.2	834	K5	1*2.2	861	K5	1*2.2	888	K6	1*2.2	914	K6	1*2.2	940
7650	K1	1*1.1	602	K2	1*1.5	633	K2	1*1.5	664	K2	1*1.5	694	K2	1*1.5	724	K3	1*1.5	753	K4	1*2.2	782	K4	1*2.2	810	K5	1*2.2	837	K5	1*2.2	864	K5	1*2.2	891	K6	1*2.2	917	K6	1*2.2	943
7800	K2	1*1.5	609	K2	1*1.5	640	K2	1*1.5	670	K2	1*1.5	700	K2	1*1.5	729	K3	1*1.5	758	K4	1*2.2	786	K5	1*2.2	814	K5	1*2.2	841	K5	1*2.2	868	K5	1*2.2	894	K6	1*2.2	920	K7	1*3.0	945
7950	K2	1*1.5	616	K2	1*1.5	646	K2	1*1.5	676	K2	1*1.5	706	K2	1*1.5	734	K4	1*2.2	763	K4	1*2.2	790	K5	1*2.2	818	K5	1*2.2	845	K5	1*2.2	871	K5	1*2.2	897	K6	1*2.2	923	K7	1*3.0	948
8100	K2	1*1.5	623	K2	1*1.5	653	K2	1*1.5	682	K2	1*1.5	711	K2	1*1.5	740	K4	1*2.2	768	K4	1*2.2	795	K5	1*2.2	822	K5	1*2.2	849	K5	1*2.2	875	K5	1*2.2	901	K7	1*3.0	926	K7	1*3.0	951
8250	K2	1*1.5	630	K2	1*1.5	659	K2	1*1.5	688	K2	1*1.5	717	K2	1*1.5	745	K4	1*2.2	773	K4	1*2.2	800	K5	1*2.2	826	K5	1*2.2	853	K5	1*2.2	879	K5	1*2.2	904	K7	1*3.0	929	K7	1*3.0	954

FX 35

Table 6.21

Air flow	100		125		150		175		200		225		250		275		300		325		350		375		400														
	Kit	P	RPM	Kit	P	RPM	Kit	P	RPM	Kit	P	RPM	Kit	P	RPM	Kit	P	RPM	Kit	P	RPM	Kit	P	RPM	Kit	P	RPM												
9000	K1	1*2.2	647	K1	1*2.2	675	K1	1*2.2	702	K2	1*2.2	729	K2	1*2.2	756	K2	1*2.2	782	K3	1*2.2	807	K3	1*2.2	833	K4	1*3.0	858	K4	1*3.0	883	K4	1*3.0	907	K5	1*3.0	931	K5	1*3.0	955
9180	K1	1*2.2	656	K1	1*2.2	683	K1	1*2.2	710	K2	1*2.2	736	K2	1*2.2	762	K2	1*2.2	788	K3	1*2.2	813	K3	1*2.2	838	K4	1*3.0	863	K4	1*3.0	888	K4	1*3.0	912	K5	1*3.0	935	K5	1*3.0	959
9360	K1	1*2.2	664	K1	1*2.2	691	K1	1*2.2	718	K2	1*2.2	744	K2	1*2.2	769	K2	1*2.2	795	K3	1*2.2	820	K4	1*3.0	844	K4	1*3.0	869	K4	1*3.0	893	K4	1*3.0	916	K5	1*3.0	940	K5	1*3.0	963
9540	K1	1*2.2	673	K1	1*2.2	699	K1	1*2.2	725	K2	1*2.2	751	K2	1*2.2	776	K2	1*2.2	801	K4	1*3.0	826	K4	1*3.0	850	K4	1*3.0	874	K4	1*3.0	898	K4	1*3.0	921	K5	1*3.0	945	K5	1*3.0	968
9720	K1	1*2.2	682	K1	1*2.2	708	K2	1*2.2	733	K2	1*2.2	758	K2	1*2.2	783	K4	1*3.0	808	K4	1*3.0	832	K4	1*3.0	856	K4	1*3.0	880	K4	1*3.0	903	K5	1*3.0	927	K5	1*3.0	949	K6	1*4.0	972
9900	K1	1*2.2	691	K1	1*2.2	716	K2	1*2.2	741	K2	1*2.2	766	K2	1*2.2	791	K4	1*3.0	815	K4	1*3.0	839	K4	1*3.0	862	K4	1*3.0	886	K4	1*3.0	909	K5	1*3.0	932	K6	1*4.0	954	K6	1*4.0	977

FX 40

P Fan motor power in kW

PERFORMANCES - OUTDOOR FAN



FXK = Heating recovery unit

OUTDOOR FAN

External static pressure (Pa)

Table 6.22

Air flow	100		125		150		175		200		225		250		275		300		325		350		375		400														
	Kit	P	RPM	Kit	P	RPM	Kit	P	RPM	Kit	P	RPM	Kit	P	RPM	Kit	P	RPM	Kit	P	RPM	Kit	P	RPM	Kit	P	RPM												
11250	K1	1*3.0	740	K1	1*3.0	763	K1	1*3.0	808	K1	1*3.0	852	K2	1*4.0	874	K2	1*4.0	895	K2	1*4.0	917	K3	1*4.0	938	K3	1*4.0	959	K3	1*4.0	980	K3	1*4.0	1000						
11475	K1	1*3.0	751	K1	1*3.0	774	K1	1*3.0	818	K2	1*4.0	840	K2	1*4.0	861	K2	1*4.0	883	K2	1*4.0	904	K2	1*4.0	925	K3	1*4.0	946	K3	1*4.0	967	K3	1*4.0	1007						
11700	K1	1*3.0	762	K1	1*3.0	784	K1	1*3.0	828	K2	1*4.0	849	K2	1*4.0	871	K2	1*4.0	892	K2	1*4.0	913	K3	1*4.0	933	K3	1*4.0	954	K3	1*4.0	974	K4	1*5.5	995	K4	1*5.5	1015			
11925	K1	1*3.0	774	K1	1*3.0	795	K5	1*4.0	817	K2	1*4.0	838	K2	1*4.0	860	K2	1*4.0	881	K2	1*4.0	901	K3	1*4.0	921	K3	1*4.0	942	K3	1*4.0	962	K4	1*5.5	982	K4	1*5.5	1002			
12150	K5	1*4.0	785	K5	1*4.0	806	K5	1*4.0	827	K2	1*4.0	848	K2	1*4.0	869	K2	1*4.0	890	K2	1*4.0	910	K3	1*4.0	930	K3	1*4.0	951	K4	1*5.5	970	K4	1*5.5	990	K4	1*5.5	1010	K4	1*5.5	1029
12375	K5	1*4.0	796	K5	1*4.0	817	K2	1*4.0	838	K2	1*4.0	859	K2	1*4.0	879	K2	1*4.0	899	K2	1*4.0	920	K3	1*4.0	939	K4	1*5.5	959	K4	1*5.5	979	K4	1*5.5	998	K4	1*5.5	1018	K4	1*5.5	1037

Table 6.23

Air flow	100		125		150		175		200		225		250		275		300		325		350		375		400											
	Kit	P	RPM	Kit	P	RPM	Kit	P	RPM	Kit	P	RPM	Kit	P	RPM	Kit	P	RPM	Kit	P	RPM	Kit	P	RPM	Kit	P	RPM									
13500	K1	1*3.0	579	K1	1*3.0	601	K1	1*3.0	646	K2	1*3.0	668	K2	1*3.0	690	K2	1*3.0	712	K3	1*4.0	733	K4	1*4.0	754	K4	1*4.0	775	K4	1*4.0	796	K4	1*4.0	816	K4	1*4.0	836
13770	K1	1*3.0	587	K1	1*3.0	609	K1	1*3.0	653	K2	1*3.0	675	K2	1*3.0	696	K3	1*4.0	718	K3	1*4.0	739	K4	1*4.0	759	K4	1*4.0	780	K4	1*4.0	800	K4	1*4.0	820	K5	1*5.5	840
14040	K1	1*3.0	595	K1	1*3.0	617	K2	1*3.0	660	K2	1*3.0	681	K3	1*4.0	702	K3	1*4.0	723	K4	1*4.0	744	K4	1*4.0	765	K4	1*4.0	785	K4	1*4.0	805	K4	1*4.0	825	K5	1*5.5	844
14310	K1	1*3.0	603	K1	1*3.0	624	K2	1*3.0	667	K3	1*4.0	688	K3	1*4.0	709	K3	1*4.0	729	K4	1*4.0	750	K4	1*4.0	770	K4	1*4.0	790	K4	1*4.0	810	K6	1*5.5	829	K5	1*5.5	849
14580	K1	1*3.0	611	K1	1*3.0	632	K2	1*3.0	674	K3	1*4.0	695	K3	1*4.0	715	K3	1*4.0	735	K4	1*4.0	756	K4	1*4.0	776	K4	1*4.0	795	K6	1*5.5	815	K6	1*5.5	834	K5	1*5.5	853
14850	K1	1*3.0	619	K1	1*3.0	640	K2	1*3.0	681	K3	1*4.0	701	K3	1*4.0	722	K3	1*4.0	742	K4	1*4.0	761	K4	1*4.0	781	K4	1*4.0	801	K6	1*5.5	820	K6	1*5.5	839	K5	1*5.5	858

Table 6.24

Air flow	100		125		150		175		200		225		250		275		300		325		350		375		400														
	Kit	P	RPM	Kit	P	RPM	Kit	P	RPM	Kit	P	RPM	Kit	P	RPM	Kit	P	RPM	Kit	P	RPM	Kit	P	RPM	Kit	P	RPM												
16875	K1	1*4.0	664	K1	1*4.0	682	K1	1*4.0	701	K2	1*5.5	719	K2	1*5.5	735	K3	1*5.5	755	K3	1*5.5	773	K3	1*5.5	791	K3	1*5.5	809	K3	1*5.5	827	K3	1*5.5	845	K3	1*5.5	862	K4	1*7.5	879
17275	K1	1*4.0	676	K1	1*4.0	694	K2	1*5.5	712	K2	1*5.5	730	K3	1*5.5	748	K3	1*5.5	766	K3	1*5.5	783	K3	1*5.5	801	K3	1*5.5	818	K3	1*5.5	836	K4	1*7.5	853	K4	1*7.5	870	K4	1*7.5	887
17675	K2	1*5.5	689	K2	1*5.5	706	K2	1*5.5	724	K2	1*5.5	741	K3	1*5.5	759	K3	1*5.5	776	K3	1*5.5	793	K3	1*5.5	811	K3	1*5.5	828	K5	1*7.5	845	K4	1*7.5	862	K4	1*7.5	879	K4	1*7.5	895
18075	K2	1*5.5	701	K2	1*5.5	718	K2	1*5.5	736	K3	1*5.5	753	K3	1*5.5	767	K3	1*5.5	787	K3	1*5.5	804	K5	1*7.5	821	K5	1*7.5	837	K4	1*7.5	854	K4	1*7.5	871	K4	1*7.5	887	K4	1*7.5	904
18475	K2	1*5.5	714	K2	1*5.5	731	K3	1*5.5	747	K3	1*5.5	764	K3	1*5.5	781	K3	1*5.5	797	K5	1*7.5	814	K5	1*7.5	831	K4	1*7.5	847	K4	1*7.5	863	K4	1*7.5	880	K4	1*7.5	896	K4	1*7.5	912
18875	K2	1*5.5	726	K2	1*5.5	743	K3	1*5.5	759	K3	1*5.5	776	K5	1*7.5	792	K5	1*7.5	808	K5	1*7.5	825	K5	1*7.5	841	K4	1*7.5	857	K4	1*7.5	873	K4	1*7.5	889	K4	1*7.5	905	K4	1*7.5	921

Table 6.25

Air flow	100		125		150		175		200		225		250		275		300		325		350		375		400											
	Kit	P	RPM	Kit	P	RPM	Kit	P	RPM	Kit	P	RPM	Kit	P	RPM	Kit	P	RPM	Kit	P	RPM	Kit	P	RPM	Kit	P	RPM									
21700	K1	2*4.0	871	K1	2*4.0	893	K1	2*4.0	915	K2	2*4.0	937	K2	2*4.0	960	K2	2*4.0	1001	K2	2*4.0	1042	K3	2*5.5	1063	K3	2*5.5	1083	K3	2*5.5	1103	K3	2*5.5	1123			
22100	K1	2*4.0	884	K1	2*4.0	906	K1	2*4.0	927	K2	2*4.0	949	K2	2*4.0	971	K2	2*4.0	1011	K2	2*4.0	1052	K3	2*5.5	1072	K3	2*5.5	1092	K3	2*5.5	1112	K3	2*5.5	1132			
22500	K1	2*4.0	897	K1	2*4.0	918	K2	2*4.0	939	K2	2*4.0	960	K2	2*4.0	981	K2	2*4.0	1022	K2	2*4.0	1063	K3	2*5.5	1082	K3	2*5.5	1102	K3	2*5.5	1122	K3	2*5.5	1141			
22900	K1	2*4.0	910	K2	2*4.0	931	K2	2*4.0	952	K2	2*4.0	972	K2	2*4.0	993	K4	2*5.5	1013	K4	2*5.5	1053	K3	2*5.5	1073	K3	2*5.5	1093	K3	2*5.5	1112	K3	2*5.5	1131	K5	2*5.5	1150
23300	K1	2*4.0	923	K2	2*4.0	943	K2	2*4.0	964	K4	2*5.5	1004	K4	2*5.5	1024	K3	2*5.5	1044	K3	2*5.5	1084	K3	2*5.5	1104	K3	2*5.5	1122	K3	2*5.5	1141	K5	2*5.5	1160			
23700	K2	2*4.0	936	K2	2*4.0	956	K4	2*5.5	996	K4	2*5.5	1016	K4	2*5.5	1036	K3	2*5.5	1056	K3	2*5.5	1094	K3	2*5.5	1113	K3	2*5.5	1132	K5	2*5.5	1151	K5	2*5.5	1170			

FX 55

FX 70

FX 85

FX 100

P Fan motor power in kW

FXK = Heating recovery unit

OUTDOOR FAN

External static pressure (Pa)

Table 6.26

Air flow	100		125		150		175		200		225		250		275		300		325		350		375		400																							
	Kit	P	RPM	Kit	P	RPM	Kit	P	RPM	Kit	P	RPM	Kit	P	RPM	Kit	P	RPM	Kit	P	RPM	Kit	P	RPM	Kit	P	RPM																					
23750	K1	2*2.2	633	K1	2*2.2	657	K2	2*3.0	681	K2	2*3.0	704	K3	2*3.0	749	K4	2*4.0	793	K4	2*4.0	815	K5	2*4.0	856	K5	2*4.0	876	K5	2*4.0	882	K5	2*4.0	882	K5	2*4.0	887	K6	2*5.5	1141	K6	2*5.5	1150	K6	2*5.5	1160	K6	2*5.5	1170
24225	K1	2*2.2	642	K2	2*3.0	665	K2	2*3.0	689	K2	2*3.0	712	K3	2*3.0	756	K4	2*4.0	800	K4	2*4.0	821	K5	2*4.0	862	K5	2*4.0	882	K5	2*4.0	887	K6	2*5.5	1141	K6	2*5.5	1150	K6	2*5.5	1160	K6	2*5.5	1170						
24700	K2	2*3.0	650	K2	2*3.0	674	K2	2*3.0	697	K2	2*3.0	719	K3	2*3.0	764	K4	2*4.0	806	K4	2*4.0	827	K5	2*4.0	868	K5	2*4.0	887	K6	2*5.5	1141	K6	2*5.5	1150	K6	2*5.5	1160	K6	2*5.5	1170									
25175	K2	2*3.0	659	K2	2*3.0	682	K2	2*3.0	705	K2	2*3.0	727	K3	2*3.0	771	K4	2*4.0	813	K5	2*4.0	834	K5	2*4.0	874	K5	2*4.0	893	K6	2*5.5	1141	K6	2*5.5	1150	K6	2*5.5	1160	K6	2*5.5	1170									
25650	K2	2*3.0	668	K2	2*3.0	691	K2	2*3.0	713	K2	2*3.0	735	K3	2*4.0	778	K4	2*4.0	820	K5	2*4.0	840	K5	2*4.0	880	K5	2*4.0	899	K6	2*5.5	1141	K6	2*5.5	1150	K6	2*5.5	1160	K6	2*5.5	1170									
26125	K2	2*3.0	677	K2	2*3.0	700	K2	2*3.0	722	K4	2*4.0	743	K4	2*4.0	786	K4	2*4.0	827	K5	2*4.0	847	K5	2*4.0	886	K6	2*5.5	905	K6	2*5.5	905	K6	2*5.5	905	K6	2*5.5	905	K6	2*5.5	905	K6	2*5.5	905						

FX 110

Table 6.27

Air flow	100		125		150		175		200		225		250		275		300		325		350		375		400																	
	Kit	P	RPM	Kit	P	RPM	Kit	P	RPM	Kit	P	RPM	Kit	P	RPM	Kit	P	RPM	Kit	P	RPM	Kit	P	RPM	Kit	P	RPM															
30000	K1	2*4.0	724	K1	2*4.0	744	K1	2*4.0	764	K2	2*5.5	803	K2	2*5.5	822	K3	2*5.5	841	K3	2*5.5	860	K3	2*5.5	878	K3	2*5.5	896	K3	2*5.5	915	K3	2*5.5	933	K4	2*7.5	950	K4	2*7.5	960	K4	2*7.5	970
30750	K1	2*4.0	738	K1	2*4.0	758	K2	2*5.5	777	K2	2*5.5	815	K2	2*5.5	834	K3	2*5.5	853	K3	2*5.5	871	K3	2*5.5	889	K3	2*5.5	907	K3	2*5.5	925	K5	2*7.5	943	K4	2*7.5	953	K4	2*7.5	963	K4	2*7.5	970
31500	K1	2*4.0	753	K2	2*5.5	772	K2	2*5.5	791	K2	2*5.5	828	K3	2*5.5	846	K3	2*5.5	864	K3	2*5.5	882	K3	2*5.5	900	K5	2*7.5	918	K5	2*7.5	935	K4	2*7.5	953	K4	2*7.5	963	K4	2*7.5	970			
32250	K2	2*5.5	767	K2	2*5.5	786	K2	2*5.5	804	K2	2*5.5	841	K3	2*5.5	859	K3	2*5.5	876	K3	2*5.5	894	K5	2*7.5	912	K5	2*7.5	929	K4	2*7.5	946	K4	2*7.5	963	K4	2*7.5	974	K4	2*7.5	980			
33000	K2	2*5.5	781	K2	2*5.5	800	K2	2*5.5	818	K3	2*5.5	853	K3	2*5.5	871	K5	2*7.5	889	K5	2*7.5	906	K5	2*7.5	923	K5	2*7.5	940	K4	2*7.5	957	K4	2*7.5	974	K4	2*7.5	980						

FX 140

Table 6.28

Air flow	100		125		150		175		200		225		250		275		300		325		350		375		400														
	Kit	P	RPM	Kit	P	RPM	Kit	P	RPM	Kit	P	RPM	Kit	P	RPM	Kit	P	RPM	Kit	P	RPM	Kit	P	RPM	Kit	P	RPM												
33750	K1	2*5.5	800	K1	2*5.5	818	K2	2*5.5	835	K2	2*5.5	853	K3	2*7.5	888	K3	2*7.5	905	K3	2*7.5	922	K3	2*7.5	939	K4	2*7.5	956	K4	2*7.5	972	K4	2*7.5	989	K4	2*7.5	1005	K4	2*7.5	1015
34425	K1	2*5.5	813	K1	2*5.5	831	K1	2*5.5	848	K2	2*5.5	865	K3	2*7.5	899	K3	2*7.5	916	K3	2*7.5	933	K3	2*7.5	950	K4	2*7.5	966	K4	2*7.5	982	K4	2*7.5	999	No Kit	No Kit	No Kit	No Kit	No Kit	
35100	K1	2*5.5	826	K5	2*7.5	844	K3	2*7.5	861	K3	2*7.5	877	K3	2*7.5	894	K3	2*7.5	911	K3	2*7.5	928	K3	2*7.5	944	K4	2*7.5	960	K4	2*7.5	977	K4	2*7.5	993	No Kit	No Kit	No Kit	No Kit	No Kit	
35775	K5	2*7.5	840	K3	2*7.5	856	K3	2*7.5	873	K3	2*7.5	890	K3	2*7.5	906	K3	2*7.5	923	K3	2*7.5	939	K4	2*7.5	955	K4	2*7.5	971	K4	2*7.5	987	No Kit	No Kit	No Kit	No Kit	No Kit	No Kit	No Kit	No Kit	
36450	K3	2*7.5	853	K3	2*7.5	870	K3	2*7.5	886	K3	2*7.5	902	K3	2*7.5	919	K3	2*7.5	935	K4	2*7.5	951	K4	2*7.5	967	No Kit	No Kit	No Kit	No Kit	No Kit	No Kit	No Kit	No Kit	No Kit	No Kit	No Kit	No Kit	No Kit	No Kit	No Kit
37125	K3	2*7.5	866	K3	2*7.5	883	K3	2*7.5	899	K3	2*7.5	915	K3	2*7.5	931	K4	2*7.5	947	K4	2*7.5	963	No Kit	No Kit	No Kit	No Kit	No Kit	No Kit	No Kit	No Kit	No Kit	No Kit	No Kit	No Kit	No Kit	No Kit	No Kit	No Kit	No Kit	No Kit

FX 170

P Fan motor power in kW

OUTDOOR NOISE LEVEL - STANDARD

Table 7.1

ESP : 150 Pa

Spectrum per octave band

FC/FH FG/FD	63	125	250	500	1000	2000	4000	8000	Sound power dB(A) (1)	Sound pressure at 10 meters dB(A) (2)
85	66	73	77	80	83	80	73	66	87	56
100	66	74	77	79	84	82	75	67	88	57
120	48	67	72	78	82	83	77	67	87	56
150	50	71	78	84	89	87	80	71	92	61
170	52	72	78	84	89	87	81	73	92	61
200	51	67	75	82	84	83	75	66	88	57
230	53	67	74	81	84	86	78	66	89	58

Table 7.2

ESP : 500 Pa

Spectrum per octave band

FC/FH FG/FD	63	125	250	500	1000	2000	4000	8000	Sound power dB(A) (1)	Sound pressure at 10 meters dB(A) (2)
85	66	74	78	80	84	80	75	68	88	57
100	66	74	78	80	84	82	76	69	88	57
120	52	69	76	79	83	83	78	70	88	57
150	53	72	79	84	89	87	81	72	92	61
170	53	72	79	83	89	87	82	73	92	61
200	58	69	76	83	84	83	76	67	89	58
230	59	70	76	82	85	86	79	68	90	59

OUTDOOR NOISE LEVEL - LOW NOISE

Table 7.3

ESP : 150 Pa

Spectrum per octave band

FC/FH FG/FD	63	125	250	500	1000	2000	4000	8000	Sound power dB(A) (1)	Sound pressure at 10 meters dB(A) (2)
85	47	69	72	76	78	74	68	63	82	51
100	49	69	70	75	76	76	73	67	82	51
120	48	64	71	76	77	75	73	67	82	51
150	50	68	74	78	77	79	76	68	84	53
170	52	68	74	79	79	81	78	71	86	55
200	51	67	75	80	82	76	73	66	85	54
230	53	68	75	79	82	77	74	66	85	54

Table 7.4

ESP : 500 Pa

Spectrum per octave band

FC/FH FG/FD	63	125	250	500	1000	2000	4000	8000	Sound power dB(A) (1)	Sound pressure at 10 meters dB(A) (2)
85	51	71	75	78	79	75	72	67	84	51
100	45	69	70	76	76	76	72	66	82	53
120	45	65	72	77	77	76	75	68	83	52
150	53	69	75	78	78	79	77	69	85	54
170	53	70	75	79	80	81	79	72	86	55
200	58	70	76	81	82	76	74	68	86	55
230	59	70	76	81	82	77	75	68	87	56

(1) total outdoor POWER levels

(2) Global Outdoor Sound PRESSURE Levels 10 m

INDOOR NOISE LEVEL - STANDARD & LOW NOISE

Table 7.5

ESP : 150 Pa

Spectrum per octave band

FC/FH	63	125	250	500	1000	2000	4000	8000	Sound power return dB(A)	Sound power supply dB(A)
85	49	64	72	77	80	81	78	71	81	85
100	52	67	75	82	84	85	83	76	85	90
120	51	66	74	81	82	84	82	75	84	89
150	55	67	77	84	85	86	84	75	86	91
170	57	69	79	87	88	89	87	79	89	94
200	60	72	76	80	80	80	75	68	82	86
230	62	74	77	82	82	82	78	71	85	88

Table 7.7

ESP : 500 Pa

Spectrum per octave band

FC/FH	63	125	250	500	1000	2000	4000	8000	Sound power return dB(A)	Sound power supply dB(A)
85	50	69	74	81	80	81	80	73	82	87
100	49	68	75	83	82	83	82	76	84	89
120	50	69	76	84	84	85	84	77	86	90
150	58	73	81	85	86	87	86	77	88	92
170	59	74	82	87	89	89	88	80	90	95
200	68	79	81	86	84	82	80	73	87	91
230	69	80	83	87	85	84	81	75	88	92

INDOOR NOISE LEVEL - STANDARD & LOW NOISE

Table 7.7

ESP : 150 Pa

Spectrum per octave band

FG/FD	63	125	250	500	1000	2000	4000	8000	Sound power return dB(A)	Sound power supply dB(A)
85	55	71	72	77	78	78	75	69	81	84
100	56	73	74	79	82	82	79	73	84	87
120	58	75	77	81	84	84	81	75	86	89
150	60	75	76	82	84	79	76	70	84	88
170	61	77	79	84	86	81	78	72	86	90
200	65	75	78	83	81	81	77	70	84	88
230	67	77	80	85	83	83	79	72	86	90

Table 7.8

ESP : 500 Pa

Spectrum per octave band

FG/FD	63	125	250	500	1000	2000	4000	8000	Sound power return dB(A)	Sound power supply dB(A)
85	62	79	83	82	84	82	80	74	86	90
100	62	78	84	83	85	84	82	76	87	91
120	63	79	86	84	87	85	84	78	89	93
150	68	82	88	86	89	85	82	76	90	94
170	68	82	88	87	91	86	83	77	91	95
200	71	82	85	88	86	84	82	75	89	93
230	71	82	86	89	88	85	83	77	90	94

INDOOR NOISE LEVEL - HIGH EFFICIENCY & LOW NOISE

Table 7.9

ESP : 150 Pa

Spectrum per octave band

FC/FH	63	125	250	500	1000	2000	4000	8000	Sound power return dB(A)	Sound power supply dB(A)
85	49	64	69	69	71	65	60	58	71	76
100	51	66	71	71	73	67	62	60	73	78
120	53	68	74	73	76	70	64	63	75	80
150	52	67	72	72	74	68	63	61	74	79
170	55	70	75	75	77	71	66	64	77	82
200	57	72	78	78	80	74	68	67	80	85
230	60	75	80	80	82	76	71	69	82	87

Table 7.10

ESP : 500 Pa

Spectrum per octave band

FC/FH	63	125	250	500	1000	2000	4000	8000	Sound power return dB(A)	Sound power supply dB(A)
85	58	73	78	78	80	74	69	67	80	85
100	59	74	79	79	81	75	70	68	81	86
120	60	75	80	80	82	76	71	70	82	87
150	60	75	80	80	82	76	71	70	82	87
170	62	77	82	82	84	78	73	71	84	89
200	62	77	83	82	85	79	73	72	84	89
230	63	78	83	83	85	79	74	73	85	90

INDOOR NOISE LEVEL - HIGH EFFICIENCY & LOW NOISE

Table 7.11

ESP : 150 Pa

Spectrum per octave band

FG/FD	63	125	250	500	1000	2000	4000	8000	Sound power return dB(A)	Sound power supply dB(A)
85	51	66	71	71	73	67	62	60	73	78
100	53	68	73	73	75	69	64	62	75	80
120	55	70	76	75	78	72	66	65	77	82
150	54	69	74	74	76	70	65	63	76	81
170	57	72	77	77	79	73	68	66	79	84
200	59	74	80	80	82	76	70	69	82	87
230	62	77	82	82	84	78	73	71	84	89

Table 7.12

ESP : 500 Pa

Spectrum per octave band

FG/FD	63	125	250	500	1000	2000	4000	8000	Sound power return dB(A)	Sound power supply dB(A)
85	60	75	80	80	82	76	71	69	82	87
100	61	76	81	81	83	77	72	70	83	88
120	62	77	82	82	84	78	73	72	84	89
150	62	77	82	82	84	78	73	72	84	89
170	64	79	84	84	86	80	75	73	86	91
200	64	79	85	84	87	81	75	74	86	91
230	65	80	85	85	87	81	76	75	87	92

FXK = Heating recovery unit

INDOOR NOISE LEVEL

ESP : 100 Pa

Table 7.9 Spectrum per octave band

FX	63	125	250	500	1000	2000	4000	8000	Sound power return dB(A)	Sound power supply dB(A)
25	54	66	74	78	80	80	72	65	85	54
30	57	69	78	81	82	81	76	68	87	56
35	51	63	73	76	78	77	70	63	83	52
40	54	65	74	78	80	78	72	65	84	53
55	58	70	78	82	84	85	77	69	89	58
70	58	70	81	82	85	85	76	69	90	59
85	63	74	84	87	89	88	81	74	94	63
100	65	76	84	89	90	89	84	76	95	64
110	61	72	81	85	87	88	79	72	92	61
140	65	76	87	89	91	90	83	76	96	65
170	68	79	89	92	93	92	86	79	98	67

PERFORMANCES - ACCESSORIES PRESSURE DROPS



FCK = Cooling only unit
FGK = Cooling only with gas fired heating

FHK = Heat pump rooftop
FDK = Heat pump rooftop with gas fired heating

Table 8

Size	Airflow	Economiser	G4 Filters	F7 Filters	UV LIGHT	Hot Water coil S	Hot Water coil H	Electric Heater S	Electric Heater M	Electric Heater H	Heating Gaz fired H	Adjustable roofcurb	Multidirectional Roofcurb	Heat Recovery Modul Fresh Air	Heat Recovery Modul exhaust air
85	12000	12	1	75	18	9	15	3	5	6	14	17	22	149	93
	15000	19	7	105	30	13	22	6	7	7	23	27	33	220	139
	23000	45	28	199	63	26	44	7	9	11	53	63	73	223	143
100	14000	17	5	94	26	11	19	6	7	8	20	23	30	194	123
	18500	29	15	143	44	18	31	8	10	11	34	41	51	318	206
	23000	45	28	199	63	26	44	11	14	16	53	63	78	223	143
120	15000	19	7	105	30	13	22	7	8	9	23	27	35	220	139
	20500	36	21	167	52	21	37	10	12	13	42	50	62	185	118
	23000	45	28	199	63	26	44	12	15	17	53	63	78	223	143
150	18000	6	1	75	15	6	10	4	5	7	16	30	35	258	193
	26000	12	12	130	33	12	19	9	10	13	33	62	72	277	179
	35000	22	29	204	54	19	33	15	18	23	59	112	131	296	194
170	21000	8	5	94	21	8	14	8	9	10	21	40	49	190	121
	30000	16	19	161	42	15	25	10	13	15	44	82	95	359	234
	35000	22	29	204	54	19	33	17	19	21	59	112	131	296	194
200	24000	12	3	88	18	7	11	16	15	14	21	53	67	241	155
	35000	26	18	154	39	13	22	22	21	20	44	112	133	296	194
	43000	39	31	211	54	19	31	24	26	29	66	169	195	376	248
230	27000	15	7	105	24	8	14	18	18	17	26	67	84	298	193
	39000	32	24	182	46	16	26	24	24	25	55	139	163	360	237
	43000	39	31	211	54	19	31	24	26	29	66	169	195	376	248

FXK = Heating recovery unit

Table 8.1

SIZE	Air flow m³/h		Hot water coil		Electric heater		Roofcurb Base frame (Pa)
			S (Pa)	H (Pa)	S (Pa)	H (Pa)	
25	Min.	3 200	6	12	3	5	5
	Nom.	4 000	9	17	6	9	5
	Max.	4 500	11	21	9	12	5
30	Min.	4 000	9	17	6	9	5
	Nom.	5 000	13	25	12	18	5
	Max.	5 500	15	30	12	18	6
35	Min.	4 800	2	4	3	3	5
	Nom.	6 000	3	6	3	3	5
	Max.	6 600	4	7	3	3	5
40	Min.	5 800	3	6	3	3	5
	Nom.	7 200	4	8	3	3	5
	Max.	8 100	5	10	3	3	5
55	Min.	7 200	4	8	3	3	5
	Nom.	9 000	6	12	3	3	5
	Max.	9 900	7	15	3	3	5
70	Min.	8 600	3	7	3	3	5
	Nom.	10 800	5	10	3	3	5
	Max.	12 200	6	13	3	3	5
85	Min.	10 800	5	10	3	3	5
	Nom.	13 500	8	15	3	6	6
	Max.	15 400	10	19	6	6	7
100	Min.	13 800	8	16	3	6	6
	Nom.	17 300	12	23	6	9	9
	Max.	18 200	13	26	6	9	10
110	Min.	15 200	5	9	3	3	5
	Nom.	19 000	7	14	3	6	5
	Max.	21 500	8	17	6	6	7
140	Min.	19 200	7	14	3	6	5
	Nom.	24 000	10	20	6	9	9
	Max.	25 500	11	23	9	9	10
170	Min.	24 000	10	20	6	9	9
	Nom.	27 000	13	25	9	9	11
	Max.	30 000	15	30	12	12	13

ELECTRICAL DATA - ELECTRICAL TABLES



Tabella 9.1

		085		100		120		150		170		200		230	
		Pa	FLA	Pa	FLA	Pa	FLA	Pa	FLA	Pa	FLA	Pa	FLA	Pa	FLA
		kW	A	kW	A	kW	A	kW	A	kW	A	kW	A	kW	A
UNIT															
basic FC / FH R410A		37,9	68,0	46,3	78,2	54,7	89,4	63,6	114,3	77,7	138,5	83,5	149,7	109,1	178,1
Compressors		31,4	56,2	37,0	62,0	45,2	72,8	51,0	91,8	62,8	112,4	68,0	122,4	90,4	145,6
Direct start up amps Id/la		3,0		3,5		3,0		2,0		2,0		2,0		2	
kit indoor standard		3,6	6,5	6,4	10,9	6,4	10,9	7,3	13,0	9,6	16,6	9,6	16,6		21,8
kit indoor high efficiency		5,7	9,0	5,7	9,0	5,7	9,0	8,6	13,5	8,6	13,5	11,4	18,0	11,4	18,0
Outdoor fan standard		2,6	4,6	2,6	4,6	2,8	5,0	5,0	8,8	5,0	8,8	5,6	10,0	5,6	10,0
Outdoor fan Low noise		2,6	4,6	2,6	4,6	2,8	5,0	5,0	8,8	5,0	8,8	5,6	10,0	5,6	10,0
ELECTRICAL															
Electric heater S		30	42	30	42	30	42	45	63	45	63	72	100	72	100
Electric heater M		54	75	54	75	54	75	72	100	72	100	108	150	108	150
Electric heater H		72	100	72	100	72	100	108	150	108	150	162	226	162	226
Kits															
Differential kits	K1	-1,0	-1,7	-3,7	-6,1	-3,7	-6,1	-3,5	-6,2	-5,8	-9,8	-2,3	-3,6	-5,5	-8,8
INDOOR	K2	0,0	0,0	-2,8	-4,4	-2,8	-4,4	-1,9	-3,4	-4,2	-7,0	-2,3	-3,6	-5,5	-8,8
KIT STANDARD 0	K3	0,0	0,0	-2,8	-4,4	-2,8	-4,4	0,0	0,0	-2,3	-3,6	0,0	0,0	-3,2	-5,2
	K4	1,2	1,8	-1,6	-2,6	-1,6	-2,6	0,0	0,0	-2,3	-3,6	3,2	5,2	0,0	0,0
	K5	1,2	1,8	-1,6	-2,6	-1,6	-2,6	2,3	3,6	0,0	0,0	3,2	5,2	0,0	0,0
	K6	5,0	8,7	2,2	4,3	2,2	4,3	2,3	3,6	0,0	0,0	7,6	13,8	4,4	8,6
	K7	2,8	4,4	0,0	0,0	0,0	0,0	2,3	30,6	0,0	0,0	3,2	5,2	0,0	0,0
	K8	9,2	15,3	6,4	10,9	6,4	10,9	5,5	8,8	3,2	5,2	0,0	0,0	-3,2	-5,2
	K9	-1,0	-1,7	-3,7	-6,1	-3,7	-6,1	5,5	8,8	3,2	5,2	7,6	13,8	4,4	8,6
	K10	2,8	4,4	0,0	0,0	0,0	0,0	0,0	0,0	-2,3	-3,6	11,0	19,6	7,8	14,4
	K11	5,0	8,7	2,2	4,3	2,2	4,3	2,3	3,6	0,0	0,0	15,4	25,6	12,2	20,4
	K12	5,0	8,7	2,2	4,3	2,2	4,3	9,9	17,4	7,6	13,8	7,6	13,8	4,4	8,6
	K13	1,2	1,8	-1,6	-2,6	-1,6	-2,6	5,5	8,8	3,2	5,2	15,4	25,6	12,2	20,4
	K14	2,8	4,4	0,0	0,0	0,0	0,0	9,9	17,4	7,6	13,8	-	-	-	-
	K15	9,2	15,3	6,4	10,9	6,4	10,9	13,3	23,2	11,0	19,6	-	-	-	-
	K16	5,0	8,7	2,2	4,3	2,2	4,3	9,9	17,4	7,6	13,8	-	-	-	-
	K17	13,6	23,9	10,8	19,5	10,8	19,5	-	-	-	-	-	-	-	-
	K18	6,0	10,1	3,2	5,7	3,2	5,7	-	-	-	-	-	-	-	-
EXTRACTION															
Extraction plug fan 600 à 100 Pa		4,4	10	4,4	10	4,4	10	4,4	10	4,4	10	6,6	15	6,6	15
Axial Extraction		0,9	1,8	0,9	1,8	0,9	1,8	1,4	2,7	1,4	2,7	1,4	2,7	1,4	2,7
UNIT															
Basic FG / FD R410A		39,7	71,1	47,2	80,3	57,9	95,1	65,9	117,9	80,9	143,7	86,7	154,9	113,5	186,7
Compressors		31,4	56,2	37,0	62,0	45,2	72,8	51,0	91,8	62,8	112,4	68,0	122,4	90,4	145,6
Direct start up amps Id/la		3,5		3,6		3,3		2,5		2,3		2,2		2	
kit indoor standard gas S & H		5,4	9,6	7,3	13,0	9,6	16,6	9,6	16,6	12,8	21,8	12,8	21,8	17,2	30,4
kit indoor high Efficiency		5,7	9,0	5,7	9,0	5,7	9,0	8,6	13,5	8,6	13,5	11,4	18,0	11,4	18,0
Outdoor fan standard		2,6	4,6	2,6	4,6	2,8	5,0	5,0	8,8	5,0	8,8	5,6	10,0	5,6	10,0
Outdoor fan Low noise		2,6	4,6	2,6	4,6	2,8	5,0	5,0	8,8	5,0	8,8	5,6	10,0	5,6	10,0
KIT															
Drive kits	K1	0	0,0	-1,9	-3,4	-4,2	-7,0	-2,3	-3,6	-5,5	-8,8	-5,5	-8,8	-9,9	-17,4
INDOOR	K2	0	0,0	-1,9	-3,4	-4,2	-7,0	0,0	0,0	-3,2	-5,2	-3,2	-5,2	-7,6	-13,8
	K3	1,9	3,4	0,0	0,0	-2,3	-3,6	3,2	5,2	0,0	0,0	0,0	0,0	-4,4	-8,6
KIT GAZ S & H	K4	1,9	3,4	0,0	0,0	-2,3	-3,6	3,2	5,2	0,0	0,0	0,0	0,0	-4,4	-8,6
	K5	1,9	3,4	0,0	0,0	-2,3	-3,6	7,6	13,8	4,4	8,6	4,4	8,6	0,0	0,0
	K6	4,2	7,0	2,3	3,6	0,0	0,0	11,0	19,6	7,8	14,4	12,2	20,4	7,8	11,8
	K7	4,2	7,0	2,3	3,6	0,0	0,0	3,2	5,2	0,0	0,0	7,8	14,4	3,4	5,8
	K8	7,4	12,2	5,5	8,8	3,2	5,2	7,6	13,8	4,4	8,6	0,0	0,0	-4,4	-8,6
	K9	4,2	7,0	2,3	3,6	0,0	0,0	11,0	19,6	7,8	14,4	4,4	8,6	0,0	0,0
	K10	7,4	12,2	5,5	8,8	3,2	5,2	15,4	25,6	12,2	20,4	7,8	14,4	3,4	5,8
	K11	11,8	20,8	9,9	17,4	7,6	13,8	-	-	-	-	12,2	20,4	7,8	11,8
	K12	12	21	10	17	8	14	-	-	-	-	-	-	-	-
	K13	7	12	6	9	3	5	-	-	-	-	-	-	-	-
EXTRACTION															
Extraction plug fan 600 à 100 Pa		4,4	10	4,4	10	4,4	10	4,4	10	4,4	10	6,6	15	6,6	15
Axial Extraction fan		0,9	1,8	0,9	1,8	0,9	1,8	1,4	2,7	1,4	2,7	1,4	2,7	1,4	2,7
GAS															
Gas (2 stages)															
Gas S kW		0,2	0,4	0,2	0,4	0,2	0,4	0,2	0,4	0,2	0,4	0,2	0,4	0,2	0,4
Gas H Kw		0,2	0,4	0,2	0,4	0,2	0,4	0,2	0,4	0,2	0,4	0,2	0,4	0,2	0,4
Gas H 100% modulation kW		0,2	0,4	0,2	0,4	0,2	0,4	0,2	0,4	0,2	0,4	0,2	0,4	0,2	0,4
ENERGY RECOVERY															
10 000 m³/ora		1,3	2,3	1,3	2,3	1,3	2,3	1,3	2,3	1,3	2,3	1,3	2,3	1,3	2,3
20 000 m³/ora		2,6	4,6	2,6	4,6	2,6	4,6	2,6	4,6	2,6	4,6	2,6	4,6	2,6	4,6
30 000 m³/h		2,6	4,6	2,6	4,6	2,6	4,6	2,6	4,6	2,6	4,6	2,6	4,6	2,6	4,6
40 000 m³/ora		12,9	23,4	12,9	23,4	12,9	23,4	12,9	23,4	12,9	23,4	12,9	23,4	12,9	23,4

Table 9.2

	SIZE	FX 25		FX 30		FX 35		FX 40		FX 55		FX 70	
		P	FLA	P	FLA	P	FLA	P	FLA	P	FLA	P	FLA
Basic unit cooling	R407C	13	23	16	29	16	29	22	38	26	44	31	50
Electric heater	S	9	13	9	13	18	26	18	26	18	26	36	53
	H	18	26	18	26	36	53	36	53	36	53	72	106
Drive kits	K 1	0	-1	-1	-1	-1	-1	-2	-3	-2	-4	-2	-3
	K 2	0	-1	-1	-1	-1	-1	-1	-2	-2	-3	-2	-3
	K 3	0	-1	-1	-1	-1	-1	-1	-2	-2	-3	-1	-2
	K 4	0	-1	-1	-1	-1	-1	-1	-1	-1	-2	-1	-2
	K 5	0	0	0	0	0	0	-1	-1	-1	-2	0	0
	K 6	0	0	0	0	1	1	0	0	-1	-2	-2	-4
	K 7	1	1	-1	-1	0	0	0	0	0	0	-1	-2
	K 8	0	0	1	1	-1	-1	-1	-1	0	0	0	0
	K 9	1	1	0	0			0	0	-1	-2	1	2
	K 10	0	0	1	1			1	2	1	2	-1	-2
	K 11											1	2
Outdoor Drive kits	K 1	0	0	0	0	-1	-1	0	0	0	0	0	0
	K 2	0	0	1	1	0	0	0	0	1	2	0	0
	K 3	1	1	1	1	0	0	0	0	1	2	1	2
	K 4	1	1	1	1	1	1	1	2	3	4	1	2
	K 5	1	2	2	3	1	1	1	2	1	2	3	4
	K 6	1	1			1	1	2	4			3	4
	K 7					2	3	1	2				
Id/Ia		3	3	3	3	3	3	3	3	3	3	3	3

Tabella 9.3

	SIZE	FX 85		FX 100		FX 110		FX 140		FX 170	
		P	FLA	P	FLA	P	FLA	P	FLA	P	FLA
Basic unit cooling	R407C	42	65	50	86	51	87	66	106	86	140
Electric heater	S	36	53	36	53	36	53	36	53	36	53
	H	72	106	72	106	72	106	72	106	72	106
Drive kits	K 1	-2	-4	-5	-9	-4	-8	-4	-7	-6	-9
	K 2	-2	-4	-4	-7	-4	-6	-4	-7	-3	-5
	K 3	-1	-2	-4	-7	-2	-3	-2	-4	-3	-5
	K 4	-1	-2	-2	-4	-2	-3	0	0	0	0
	K 5	-1	-2	-2	-4	0	0	-2	-4	0	0
	K 6	0	0	0	0	0	0	0	0	0	0
	K 7	0	0	-2	-4	2	4	3	5	4	9
	K 8	2	3					3	5		
	K 9	2	3								
	K 10										
	K 11										
Outdoor Drive kits	K 1	0	0	0	0	-2	-3	0	0	0	0
	K 2	2	3	0	0	0	0	3	5	0	0
	K 3	2	3	3	5	0	0	3	5	4	9
	K 4	4	7	3	5	2	4	8	14	4	9
	K 5	4	7	3	5	2	4	8	14	4	9
	K 6					6	9				
Id/Ia		3	3	3	3	3	3	3	3	3	3

P = Max. absorbed power in kW

FLA = Full load amps - A= Ia

Id/Ia = Startup amps/full load amps - A

GENERAL CUSTOMER CONNECTION DIAGRAM

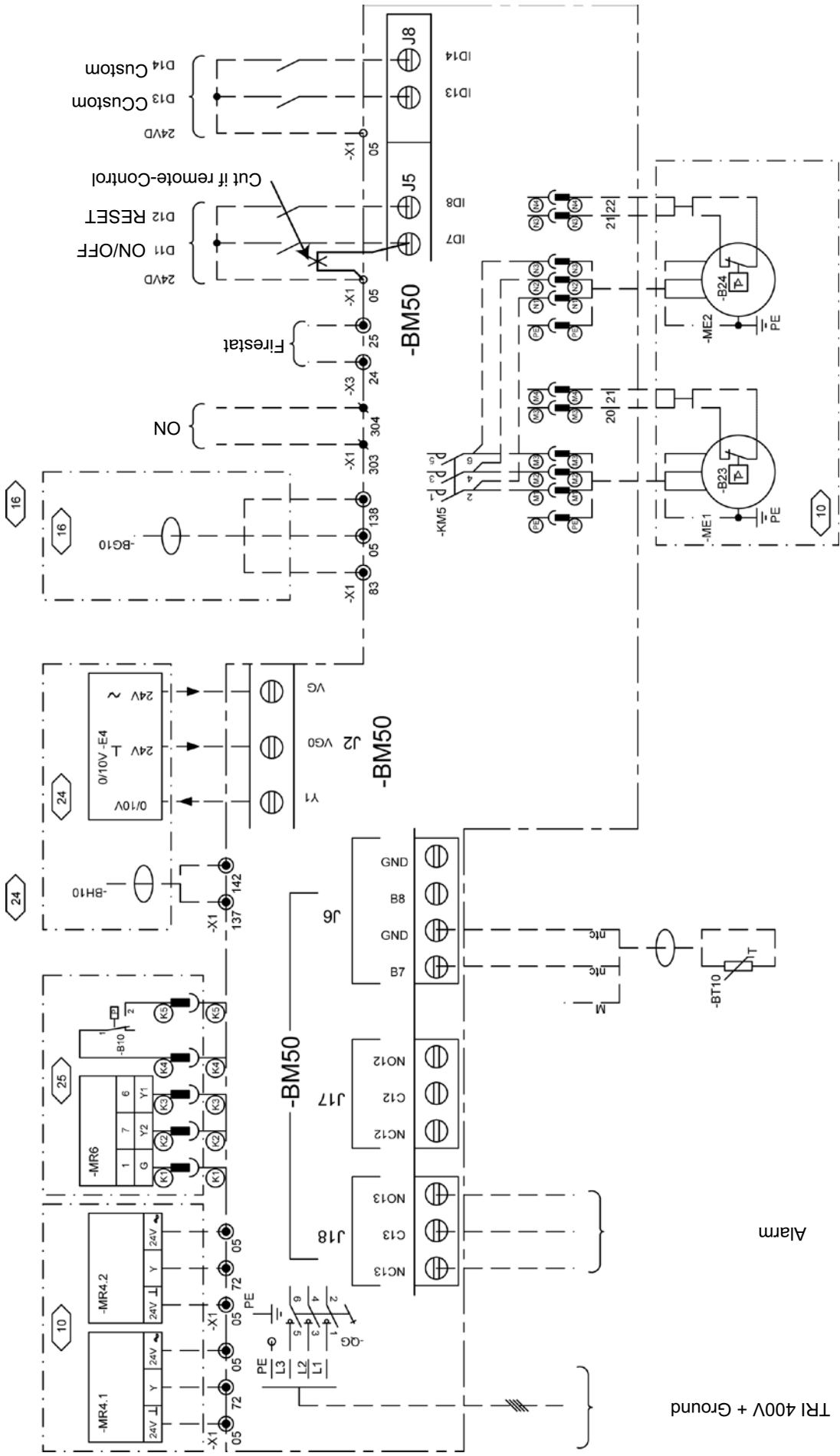

CUSTOMER CONNECTION WITH TCB

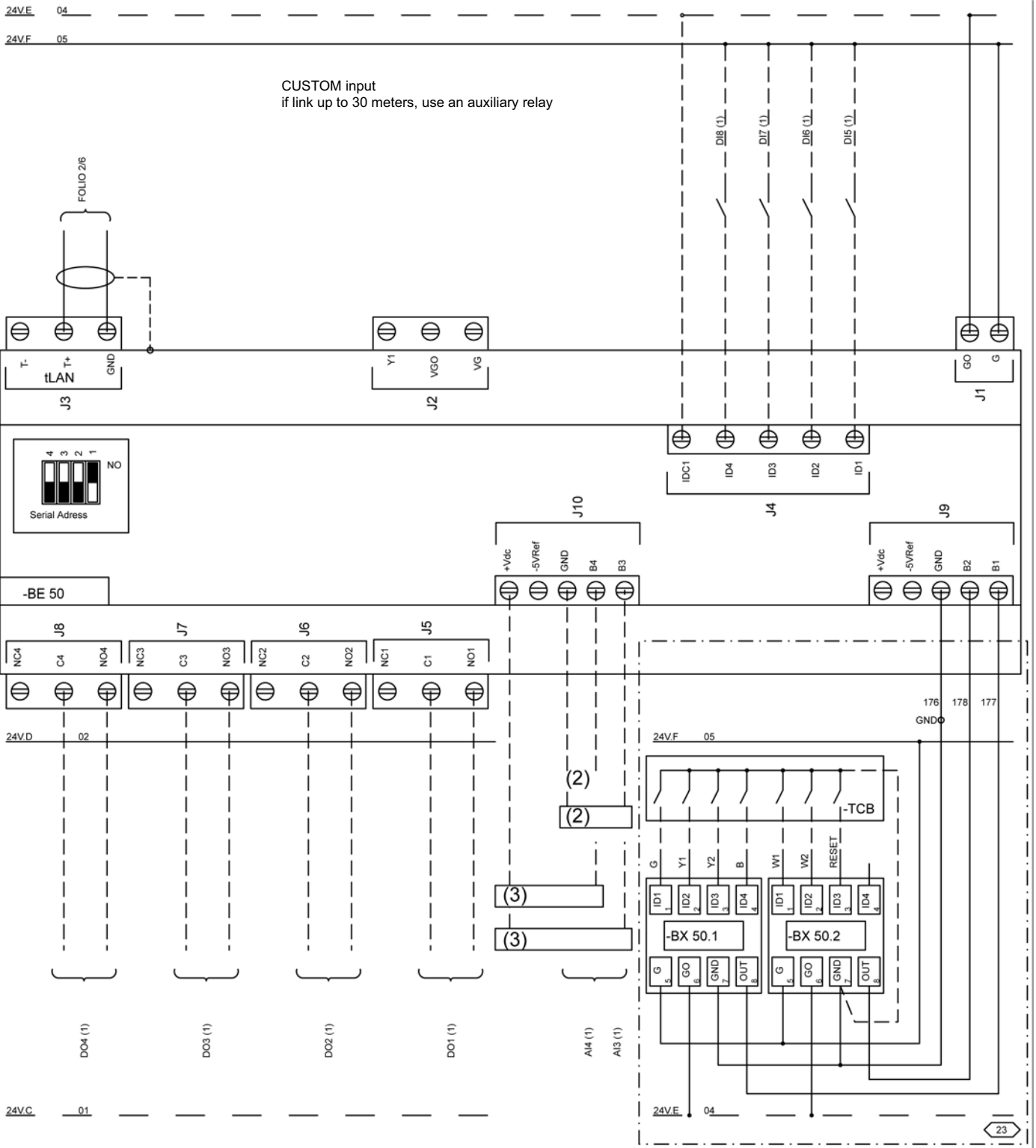

- (1) Custom
- (2) Probe
- (3) Sensor 4/20 mA

DS 50 : Service display / DC 50 : Comfort display

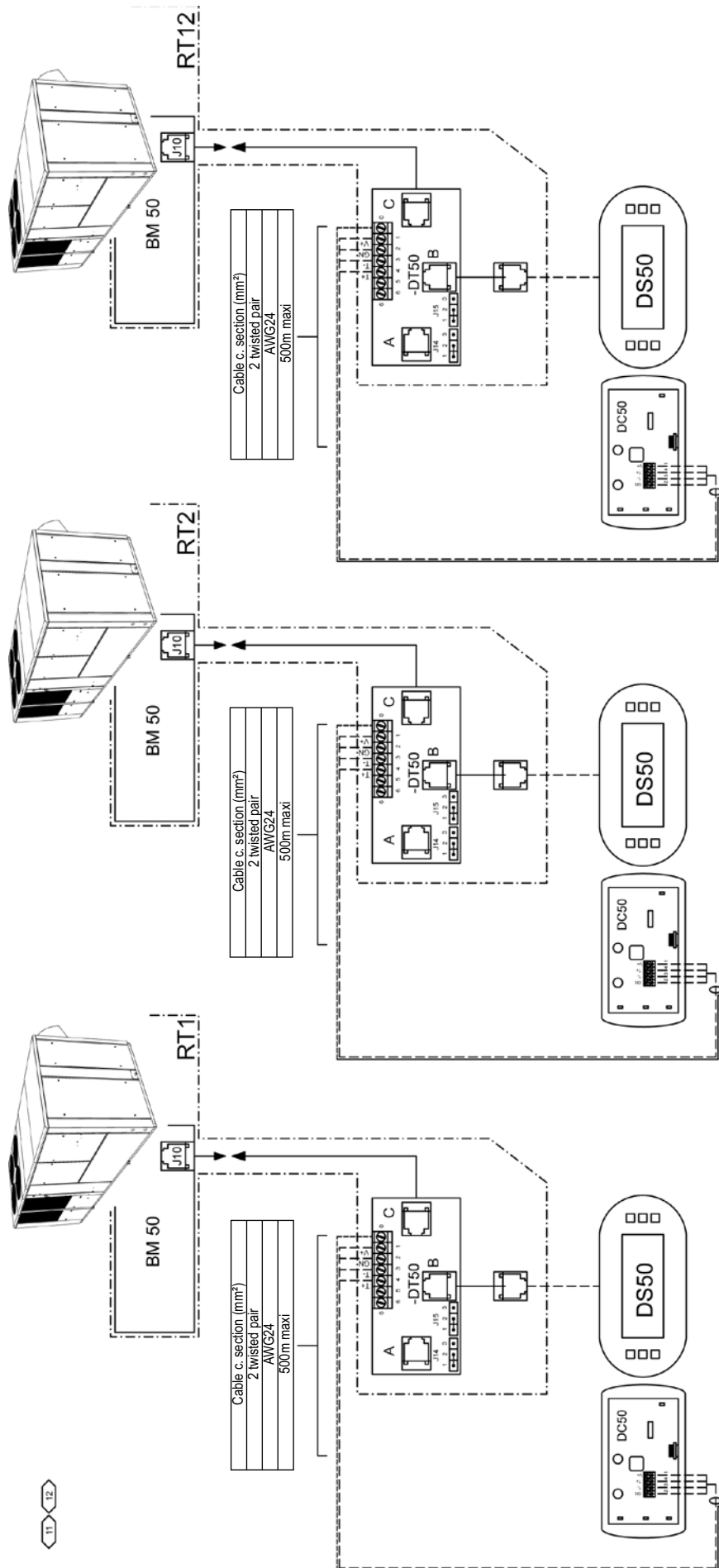

ADALINK

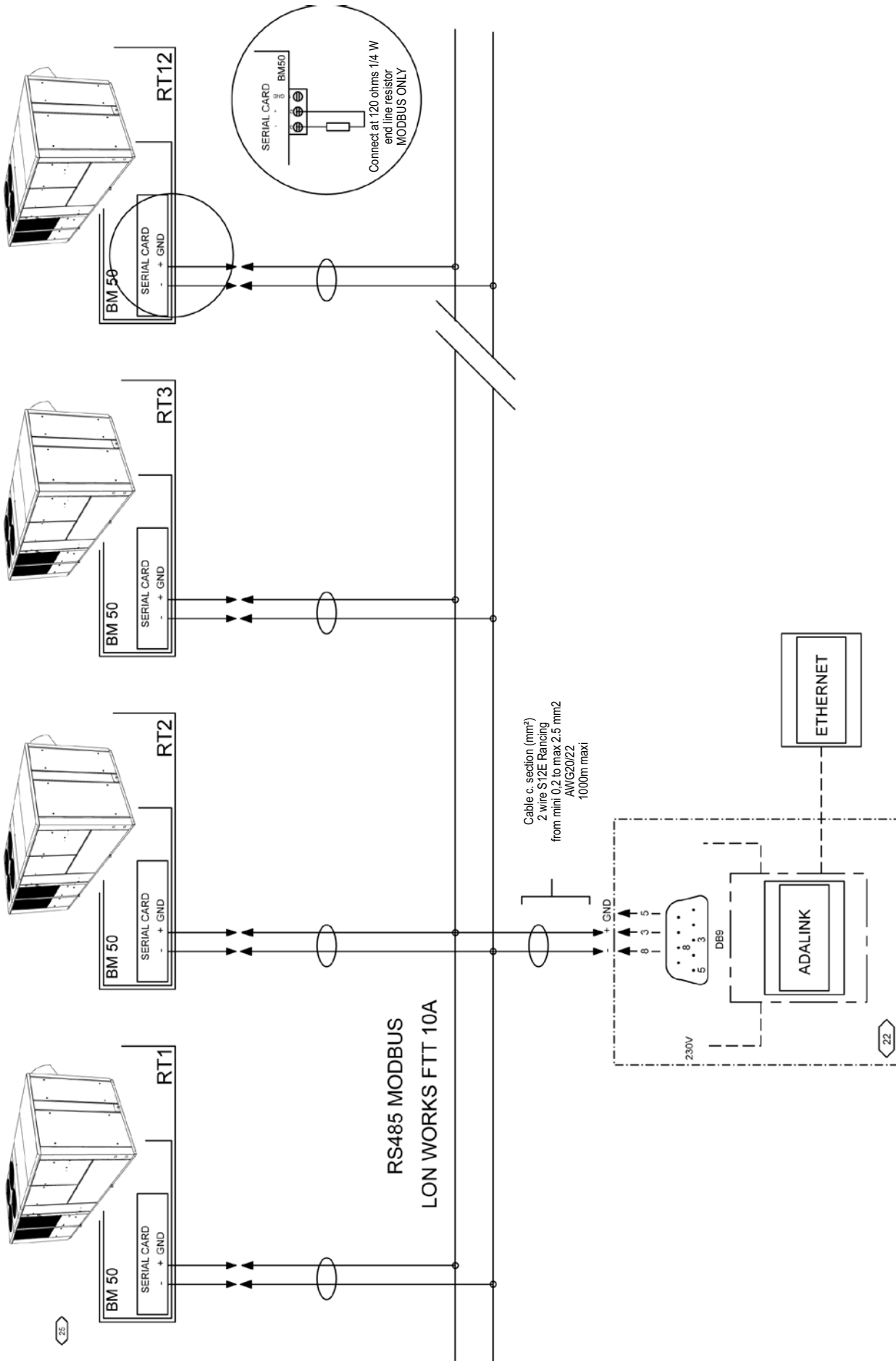

Master/Slave

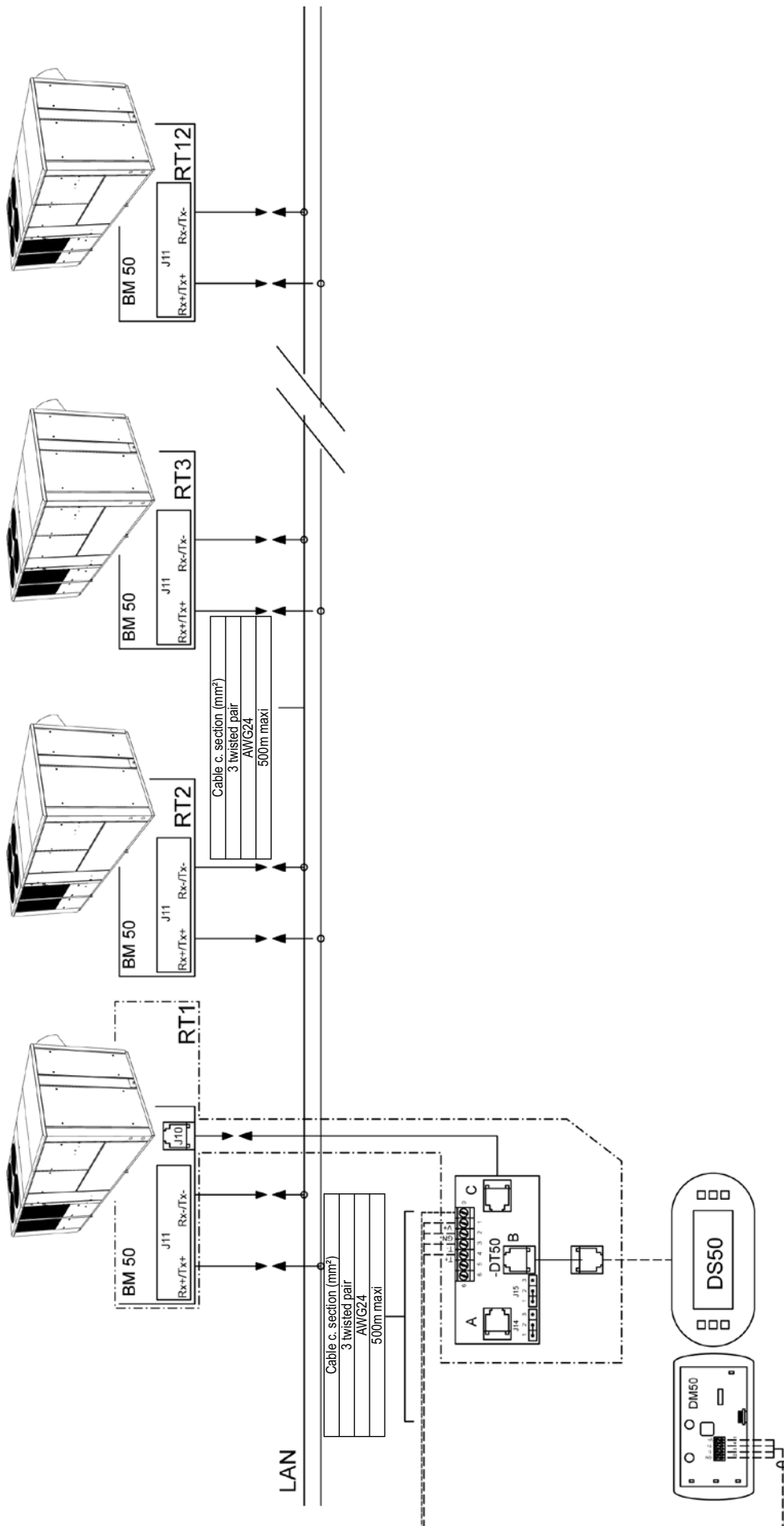

STANDARD

Logical Output Board (1 output : 1 assigned)

DO 1 - Alarm, General

Logical Input Board (4 inputs : 2 assigned, 2 customized)

DI 1 - ON/OFF

DI 2 - Reset alarm

DI 3 & 4 - Customized

(choose, for each input (2) between those 12 possibilities)

- Disable, Compressors & Heaters
- Disable 100% Compressors
- Disable 50% Compressors
- Disable, Heaters
- Disable, Cooling
- Disable, Heating
- Fault contact, Humidifier
- All return air
- 20 % Fresh air
- 30 % Fresh air
- 40 % Fresh air
- 50 % Fresh air
- All fresh air
- Activation A zone
- Activation B zone
- Activation C zone
- Activation Unoccupied zone
- Activation BMS zone
- Free, for BMS

} Those contacts
add up

ADVANCED CONTROL PACK OR TCB

Logical Output Board (4 outputs : 0 assigned, 4 customized)

DO 3 to 6 - Customized (choose, for each input (4) between those 7 possibilities)

- Alarm, Filters
- Alarm, Blower
- Alarm, Compressors
- Activation Gas
- Alarm, Heaters
- Alarm, Hot Water Coil Freezing
- Smoke alarm
- Heating mode
- Activation A zone
- Activation B zone
- Activation C zone
- Activation Unoccupied zone
- Activation BMS zone
- Free, for BMS

Logical Input Board (4 outputs: 0 assigned, 4 customized)

DI 5 to 8 - Customized

(choose, for each input (4) between those 12 possibilities)

- Disable, Compressors & Heaters
- Disable, 100% Compressors
- Disable, 50% Compressors
- Disable, Heaters
- Disable, Cooling
- Disable, Heating
- Fault contact, Humidifier
- All return air
- 20 % Fresh air
- 30 % Fresh air
- 40 % Fresh air
- 50 % Fresh air
- All Fresh Air
- Activation A zone
- Activation B zone
- Activation C zone
- Activation Unoccupied zone
- Activation BMS zone
- Free, for BMS

} Those contacts
add up

Analogue Input Board (4 outputs : 0 assigned, 2 customized)

AI 1 & 2 - Customized

(choose, for each input (4) between those 4 possibilities)

- Override room temp set point -5 +5°C (4-20mA)
- Override min. fresh air set point 0-100% (4-20mA)
- Weather sensor, Temperature
- Weather sensor, Humidity
- Free temperature (NTC probe)
- Free relative humidity (4-20mA)

Lennox Climatic 50 and BMS Modbus, Trend or BACnet.

Specification of the Bus:

Type:

➤ RS485

Speed: (Adjustable on Climatic 50 via display DS50; Setting 3933)

➤ 1200

➤ 2400

➤ 4800

➤ 9600

➤ 19200

Parity: Fixed

➤ no parity (N)

Length: Fixed

➤ 8 bits (8)

Stop bit: Fixed

➤ 2 bits (2)

Spécification du protocole:

Mode: Fixed

➤ R.T.U. for Modbus

Address of slave: (Adjustable on Climatic 50 via display DS50; Setting 3931)

➤ 1

➤ to 200

Supported functions, for Modbus:

➤ Reading Bits : 1 or 2

➤ Reading Words : 3 or 4

➤ Writing simple Bit : 5

➤ Writing simple Word : 6

Functionality 'Watchdog' on Climatic 50.

The automat Climatic 50 being passive on the bus it cannot detect any cut of communication with the BMS. From where in the event of cut of communication the Roof-Top would continue to function with the last adjustments emitted by the BMS. To avoid operation, penalizing the correct operation of the Roof-Top, the BMS must regularly write in the word 01h a value different from 0. The automat Climatic 50 decreases the value of the word 01h of 5 units every 5 seconds.

If the BMS writes the value 1000 in the word 01h, in the event of cut of communication at the end of 16 minutes 40 seconds the instructions emitted by the BMS are not taken more into account by the software of the automat Climatic 50. I.e. the following points are not took into account by the program of the automat Climatic 50 if the word 01h is equal to 0

Points concerned with the word 01h

Words :

➤ 02H / 03H / 04H / 05H / 06H / 07H / 08H

Bits :

➤ 03H / 04H / 06H / 07H / 08H / 09H / 0AH / 0BH / 0CH / 0DH / 0EH

This functionality does not prohibit the writing of the bit or of the word, those are always readable on our display DS50 (show in mode BMS via the key 'Prg')

MODBUS - BACNET

Bits R = Read / W = Write / L = Logical					
@ (hexa)	@ (deci)				DS50
01H	1	R/W	L	[On / Off] Unit	3111
02H	2	R/W	L	[Reset] Discharges the safety measures of the unit	3112
03H	3	R/W	L	[Enable] Stopping and running of the Fan Blower.[Off] the blower is stopped, [On] the blower is running.	3351 (BMS)
04H	4	R/W	L	[Enable] Stopping and running of the fan in the «Control Dead Zone». [Off] the blower is stopped, [On] the blower is running.	3352 (BMS)
05H	5	R/W	L	[BMS] Activation of the Inoccupation mode [Off] occupation mode - [On] inoccupation mode	3935
06H	6	R/W	L	[Room regulation] Choices of the priority of regulation in Heating - [Off] Heat Pump then Hot water coil or Electric or Gas [On] Hot water coil or Electric or Gas then Heat Pump	3324 (BMS)
07H	7	R/W	L	[F-Air Reheat] Activate reheating of the fresh air in the dead zone to maintain supply temperature.	3331 (BMS)
08H	8	R/W	L	[F-Air Reheat] Choices of the priority of regulation in Heating - [Off] Heat Pump then Hot water coil or Electric or Gas [On] Hot water coil or Electric or Gas then Heat Pump	3332 (BMS)
09H	9	R/W	L	[Enable] Run eco: [On] the Economiser is running, [Off] the Economiser if stopped.	3353 (BMS)
0AH	10	R/W	L	[Enable] Run CO2 Sensor: [On] Switch-on the CO2 control on a Zone, [Off] Stop the CO2 control on a zone.	3354 (BMS)
0BH	11	R/W	L	[Enable] [OFF] Force the unloading of compressors in cooling mode.	3355 (BMS)
0CH	12	R/W	L	[Enable] [OFF] Force the unloading of compressors in heating mode.	3356 (BMS)
0DH	13	R/W	L	[Enable] [OFF] Force the unloading of heating module (electric, gas or heat water coil)	3357 (BMS)
0EH	14	R/W	L	[Enable] [OFF] Force the unloading of humidity control.	3358 (BMS)
0FH	15	R/W	L	not used	
10H	16	R/W	L	[Clock] [OFF] read hour & minute [ON] write hour & minute	...
11H	17	R/W	L	[Dry contact] Digital Output, Free 1, BM50-J17-NO12	2141
12H	18	R/W	L	[Dry contact] Digital Output, Free 2, BE50-J5-NO1	2142
13H	19	R/W	L	[Dry contact] Digital Output, Free 3, BE50-J6-NO2	2143
14H	20	R/W	L	[Dry contact] Digital Output, Free 4, BE50-J7-NO3	2144
15H	21	R/W	L	[Dry contact] Digital Output, Free 5, BE50-J8-NO4	2145
16H	22	R/W	L	not used	
17H	23	R/W	L	not used	
18H	24	R/W	L	not used	
19H	25	R/W	L	not used	
1AH	26	R/W	L	not used	
1BH	27	R/W	L	not used	
1CH	28	R/W	L	not used	
1DH	29	R/W	L	not used	
1EH	30	R/W	L	not used	
1FH	31	R/W	L	not used	
20H	32	R/W	L	not used	
21H	33	R	L	[Alarm] General	1000
22H	34	R	L	[On/Off] Fan, Blower	2315
23H	35	R	L	[On/Off] Fan, Extraction	2321
24H	36	R	L	[On/Off] Compressor, 1	2516
25H	37	R	L	[On/Off] Compressor, Heat pump, 1	2517
26H	38	R	L	[On/Off] Compressor, 2	2526
27H	39	R	L	[On/Off] Compressor, Heat pump, 2	2527
28H	40	R	L	[On/Off] Compressor, 3	2536

MODBUS - BACNET

29H	41	R	L	[On/Off] Compressor, Heat pump, 3	2537
2AH	42	R	L	[On/Off] Compressor, 4	2546
2BH	43	R	L	[On/Off] Compressor, Heat pump, 4	2547
2CH	44	R	L	[On/Off] Gas, Burner, 1	2615
2DH	45	R	L	[On/Off] Gas, Burner, 2	2616
2EH	46	R	L	[On/Off] Gas, Burner, High power, 1	2617
2FH	47	R	L	[On/Off] Electrical heaters, 1	2625
30H	48	R	L	[On/Off] Electrical heaters, 2	2626
31H	49	R	L	[Dry contact] Digital Input, Free 1, BM50-J8-ID13	2151
32H	50	R	L	[Dry contact] Digital Input, Free 2, BM50-J8-ID14	2152
33H	51	R	L	[Dry contact] Digital Input, Free 3, BE50-J4-ID1	2153
34H	52	R	L	[Dry contact] Digital Input, Free 4, BE50-J4-ID2	2154
35H	53	R	L	[Dry contact] Digital Input, Free 5, BE50-J4-ID3	2155
36H	54	R	L	[Dry contact] Digital Input, Free 6, BE50-J4-ID4	2156
37H	55	R	L	not used	
38H	56	R	L	not used	
39H	57	R	L	not used	
3AH	58	R	L	not used	
3BH	59	R	L	not used	
3CH	60	R	L	not used	
3DH	61	R	L	not used	
3EH	62	R	L	not used	
3FH	63	R	L	not used	
40H	64	R	L	not used	

MODBUS - BACNET

Words R = Read / W = Write / L = Logical					
@ (hexa)	@ (deci)				DS50
01H	1	R/W	1 = 1 s	[BMS] Activation of the control by a computer or an automat - mode BMS is activated if this value is different from zero, This value is decreased every second	3934
02H	2	R/W	10 = 1.0°C	[Occupation][Room SP] Required maximum room temperature in °C. Cooling set point	3322 (BMS)
03H	3	R/W	10 = 1.0°C	[Occupation][Room SP] Required minimum room temperature in °C. Heating set point	3323 (BMS)
04H	4	R/W	1 = 1%	[Room SP] Required room minimum fresh air rate in % Middle of the dead zone.	3312 (BMS)
05H	5	R/W	10 = 1.0°C	[Inoccupation][Room SP] Required maximum room temperature in °C. Cooling set point	3322 (Uno)
06H	6	R/W	10 = 1.0°C	[Inoccupation][Room SP] Required minimum room temperature in °C. Heating set point	3323 (Uno)
07H	7	R/W	10 = 1.0%	[Humidity] Desired Maximum relative humidity in Room (in %). – Dehumidification set	3341 (BMS)
08H	8	R/W	10 = 1.0%	[Humidity] Desired Minimum relative humidity in Room (in %). – Humidification set point.	3342 (BMS)
09H	9	R/W		not used	
0AH	10	R/W		not used	
0BH	11	R/W		not used	
0CH	12	R/W	1 = 1h	[Clock] Hour	3121
0DH	13	R/W	1 = 1m	[Clock] Minute	3122
0EH	14	R/W	1 = 1	[Clock] Day of the month	3123
0FH	15	R/W	1 = 1	[Clock] Month	3124
10H	16	R/W	1 = 2001	[Clock] Year	3125
11H	17	R/W	10 = 1.0°C	[BMS] Room temperature coming from the BMS	2824
12H	18	R/W	10 = 1.0%	[BMS] Room humidity coming from the BMS	2828
13H	19	R/W	10 = 1.0°C	[BMS] Outdoor temperature coming from the BMS	2814
14H	20	R/W	10 = 1.0%	[BMS] Outdoor humidity coming from the BMS	2818
15H	21	R/W		not used	
16H	22	R/W		not used	
17H	23	R/W		not used	
18H	24	R/W		not used	
19H	25	R/W		not used	
1AH	26	R/W		not used	
1BH	27	R/W		not used	
1CH	28	R/W		not used	
1DH	29	R/W		not used	
1EH	30	R/W		not used	
1FH	31	R/W		not used	
20H	32	R/W		not used	
21H	33	R	1 = 1	[Alarm] Code Error	1000
22H	34	R	10 = 1.0°C	[Temperature] Room	2112
23H	35	R	10 = 1.0°C	[Temperature] Outdoor	2111
24H	36	R	10 = 1.0°C	[Temperature] Supply	2113
25H	37	R	10 = 1.0°C	[Temperature] Return	2114
26H	38	R	10 = 1.0%	[Relative Humidity] Room	2122
27H	39	R	10 = 1.0 g/Kg	[Absolute Humidity] Room	2124
28H	40	R	10 = 1.0%	[Relative Humidity] Outdoor	2121

MODBUS - BACNET

29H	41	R	10 = 1.0 g/Kg	[Absolute Humidity] Outdoor	2123
2AH	42	R	1 = 1 pa	[Flow] Differential pressure on the air, in pascal	2131
2BH	43	R	1 = 1 ppm	[CO ₂] Level in ppm	2132
2CH	44	R	1 = 1%	[% of opening] Register of fresh air	2413
2DH	45	R	1 = 1%	[% of opening] Valve gas	2618
2EH	46	R	1 = 1%	[% of opening] Electrical heaters (Triac)	2627
2FH	47	R	1 = 1%	[% of opening] Hot water coil	2633
30H	48	R	1 = 1%	[% of opening] Humidifier	2714
31H	49	R	10 = 1.0°C	[Dry contact] Temperature, Free 1, BE50-J9-B1	2161
32H	50	R	10 = 1.0°C	[Dry contact] Temperature, Free 2, BE50-J9-B2	2162
33H	51	R	10 = 1.0°C	[Dry contact] Temperature, Free 3, BE50-J10-B3	2163
34H	52	R	10 = 1.0°C	[Dry contact] Temperature, Free 4, BE50-J10-B4	2164
35H	53	R	10 = 1.0%	[Dry contact] Humidity, Free 1, BE50-J9-B1	2165
36H	54	R	10 = 1.0%	[Dry contact] Humidity, Free 2, BE50-J9-B2	2166
37H	55	R	10 = 1.0%	[Dry contact] Humidity, Free 3, BE50-J10-B3	2167
38H	56	R	10 = 1.0%	[Dry contact] Humidity, Free 4, BE50-J10-B4	2168
39H	57	R	1 = 1 h	[Running Time, Count] Fan, Blower	2318
3AH	58	R	1 = 1 h	[Running Time, Count] Compressor, 1	2519
3BH	59	R	1 = 1 h	[Running Time, Count] Compressor, 2	2529
3CH	60	R	1 = 1 h	[Running Time, Count] Compressor, 3	2539
3DH	61	R	1 = 1 h	[Running Time, Count] Compressor, 4	2549
3EH	62	R	bit	[Alarm] bit.0 = Air Flow bit.1 = Dirty Filters bit.2 = No Filters bit.3 = Electrical heaters bit.4 = High Temperature, Supply bit.5 = Low Temperature, Room bit.6 = Gas Burner 1 bit.7 = Gas Burner 2 bit.8 = Low Temperature, Supply bit.9 = High Temperature, Room bit.10 = Humidifier bit.11 = Low Humidity, Room bit.12 = High Humidity, Room bit.13 = Pump bit.14 = Real Time Clock bit.15 = BE50	...
3FH	63	R	bit	[Alarm] bit.0 = Probes & Sensors bit.1 = Fan, Blower bit.2 = Low Temperature, Condenser Water bit.3 = High Temperature, Condenser Water bit.4 = Flow Switch, Condenser Water bit.5 = Smoke Detector bit.6 = Fans, Condenser bit.7 = Compressor 1, H.P. & I.P. bit.8 = Compressor 1, L.P. bit.9 = Compressor 2, H.P. & I.P. bit.10 = Compressor 2, L.P. bit.11 = Compressor 3, H.P. & I.P. bit.12 = Compressor 3, L.P. bit.13 = Compressor 4, H.P. & I.P. bit.14 = Compressor 4, L.P. bit.15 =	...
40H	64	R		not used	

ECHELON Settings and Readings

			DS50
R/W	L	[On / Off] Unit	3111
R/W	L	[Reset] Discharges the safety measures of the unit	3112
R/W	L	[BMS] Activation of the Inoccupation mode [Off] occupation mode - [On] inoccupation mode	3933
R/W	L	[Clock] [OFF] read hour & minute [ON] write hour & minute	...
R	L	[Alarm] General	1000
R	L	[On/Off] Fan, Blower	2315
R	L	[On/Off] Compressor, 1	2516
R	L	[On/Off] Compressor, Heat pump, 1	2517
R	L	[On/Off] Compressor, 2	2526
R	L	[On/Off] Compressor, Heat pump, 2	2527
R	L	[On/Off] Compressor, 3	2536
R	L	[On/Off] Compressor, Heat pump, 3	2537
R	L	[On/Off] Compressor, 4	2546
R	L	[On/Off] Compressor, Heat pump, 4	2547
R	L	[On/Off] Gas, Burner, 1	2615
R	L	[On/Off] Gas, Burner, 2	2616
R	L	[On/Off] Gas, Burner, High power, 1	2617
R	L	[On/Off] Electrical heaters, 1	2625
R	L	[On/Off] Electrical heaters, 2	2626

			DS50
R/W	1 = 1 s	[BMS] Activation of the control by a computer or an automat - mode BMS is activated if this value is different from zero, This value is decreased every second	3932
R/W	10 = 1,0°C	[Occupation][Room SP] Required maximum room temperature in °C. Cooling set point	3322 (BMS)
R/W	10 = 1,0°C	[Occupation][Room SP] Required minimum room temperature in °C. Heating set point	3323 (BMS)
R/W	1 = 1%	[Room SP] Required room minimum fresh air rate in %. Middle of the dead zone	3312 (BMS)
R/W	10 = 1,0°C	[Inoccupation][Room SP] Required maximum room temperature in °C. Cooling set point	3322 (Uno)
R/W	10 = 1,0°C	[Inoccupation][Room SP] Required minimum room temperature in °C. Heating set point	3323 (Uno)
R/W	1 = 1%	[Humidity] Desired Maximum relative humidity in Room (in %). – Dehumidification set point	3341 (BMS)
R/W	1 = 1%	[Humidity] Desired Minimum relative humidity in Room (in %). – Humidification set point	3342 (BMS)
R/W	1 = 1h	[Clock] Hour	3121
R/W	1 = 1m	[Clock] Minute	3122
R/W	1 = 1	[Clock] Day of the month	3123
R/W	1 = 1	[Clock] Month	3124
R	1 = 1	[Alarm] Code Error	1000
R	10 = 1,0°C	[Temperature] Room	2112
R	10 = 1,0°C	[Temperature] Outdoor	2111
R	10 = 1,0°C	[Temperature] Supply	2113
R	10 = 1,0%	[Relative Humidity] Outdoor	2121
R	10 = 1,0 g/Kg	[Absolute Humidity] Outdoor	
R	10 = 1,0%	[Relative Humidity] Room	
R	10 = 1,0 g/Kg	[Absolute Humidity] Room	
R	1 = 1%	[% of opening] Register of fresh air	
R	1 = 1%	[% of opening] Valve gas	
R	1 = 1%	[% of opening] Electrical heaters (Triac)	
R	1 = 1%	[% of opening] Hot water coil	

PRINCIPLE SKETCHES

BCD1.2	CONDENSER COIL	-B61-B62	COMPRESSOR -MG1-MG2 HIGH PRESSURE CONTROL SWITCH
BEC	HOT WATER COIL	-MC1-MC2	CONDENSER -MC1-MC2 FAN MOTOR
BEV	EVAPORATOR COIL	-MC3-MC4	CONDENSER -MC3-MC4 FAN MOTOR
CA1.2	CHECK VALVE	-MG11-MG12	COMPRESSOR -MG1-MG2
DT1.2	THERMOSTATIC EXPANSION VALVE	-MG21-MG22	COMPRESSOR -MG1-MG2
FD1.2	FILTER DRIER	-MS1-2	BLOWER FAN MOTOR -MS1
-B14-B15	HOT WATER BATTERY ANTIFREEZE THERMOSTAT	VAM1.2	MANUAL CHECK VALVE
-BT12	BLOWER TEMPERATURE PROBE	VRM	VANNE DE REGLAGE MANUELLE
-BT17	RETURN REGULATION TEMPERATURE SENSOR	-YV2	HOT WATER 3-WAY VALVE
-B41-B42	COMPRESSOR -MG1-MG2 HIGH PRESSURE SAFETY SWITCH	-YV11-YV12	COMPRESSOR -MG1-MG2 CYCLE REVERSAL VALVE
-B51-B52	COMPRESSOR -MG1-MG2 LOW PRESSURE SAFETY SWITCH		

FC 085 - 100 -120

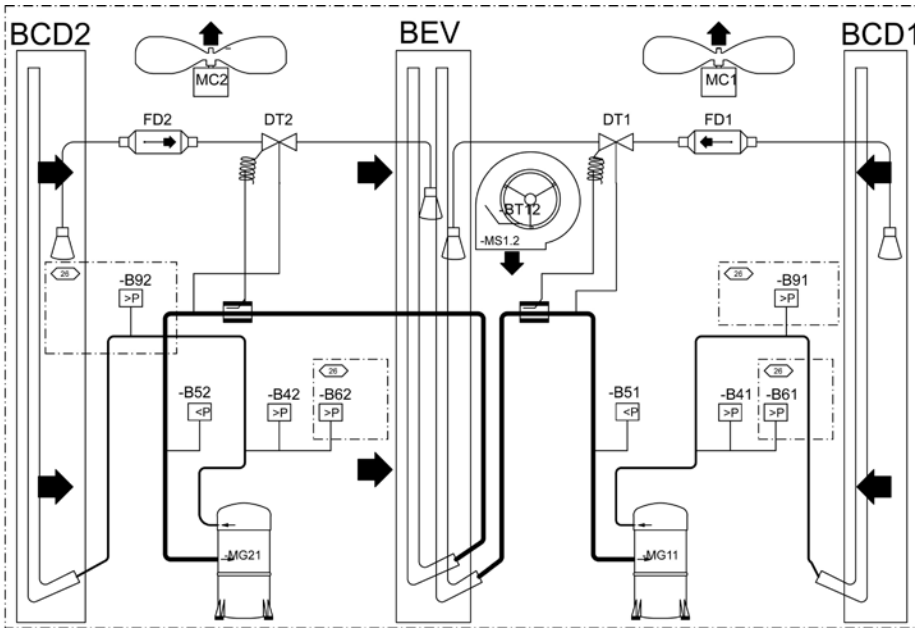

FH 085 - 100 -120

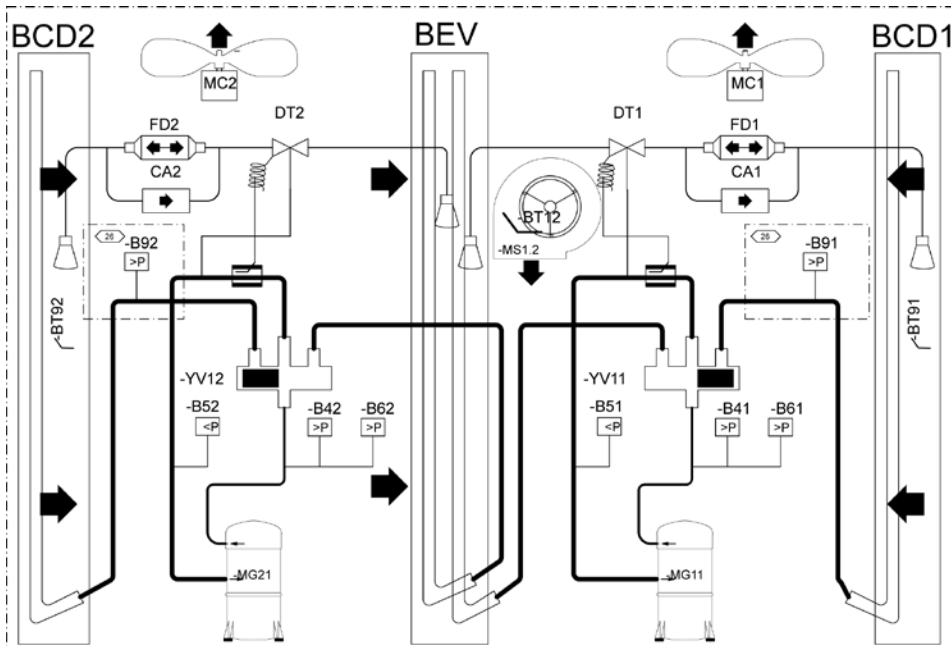

PRINCIPLE SKETCHES



- BCD1.2 CONDENSER COIL
- BEC HOT WATER COIL
- BEV EVAPORATOR COIL
- CA1.2 CHECK VALVE
- DT1.2 THERMOSTATIC EXPANSION VALVE
- FD1.2 FILTER DRIER
- B14-B15 HOT WATER BATTERY ANTIFREEZE THERMOSTAT
- BT12 BLOWER TEMPERATURE PROBE
- BT17 RETURN REGULATION TEMPERATURE SENSOR
- B41-B42 COMPRESSOR -MG1-MG2 HIGH PRESSURE SAFETY SWITCH
- B51-B52 COMPRESSOR -MG1-MG2 LOW PRESSURE SAFETY SWITCH

- B61-B62 COMPRESSOR -MG1-MG2 HIGH PRESSURE CONTROL SWITCH
- MC1-MC2 CONDENSER -MC1-MC2 FAN MOTOR
- MC3-MC4 CONDENSER -MC3-MC4 FAN MOTOR
- MG11-MG12 COMPRESSOR -MG1-MG2
- MG21-MG22 COMPRESSOR -MG1-MG2
- MS1-2 BLOWER FAN MOTOR -MS1
- VAM1.2 MANUAL CHECK VALVE
- VRM VANNE DE REGLAGE MANUELLE
- YV2 HOT WATER 3-WAY VALVE
- YV11-YV12 COMPRESSOR -MG1-MG2 CYCLE REVERSAL VALVE

FC 150

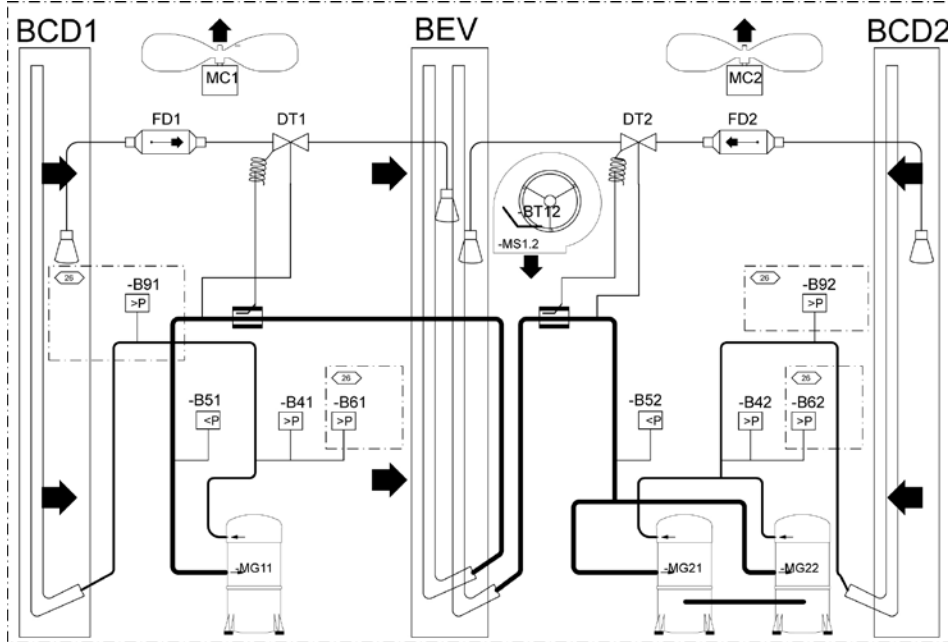

FH 150

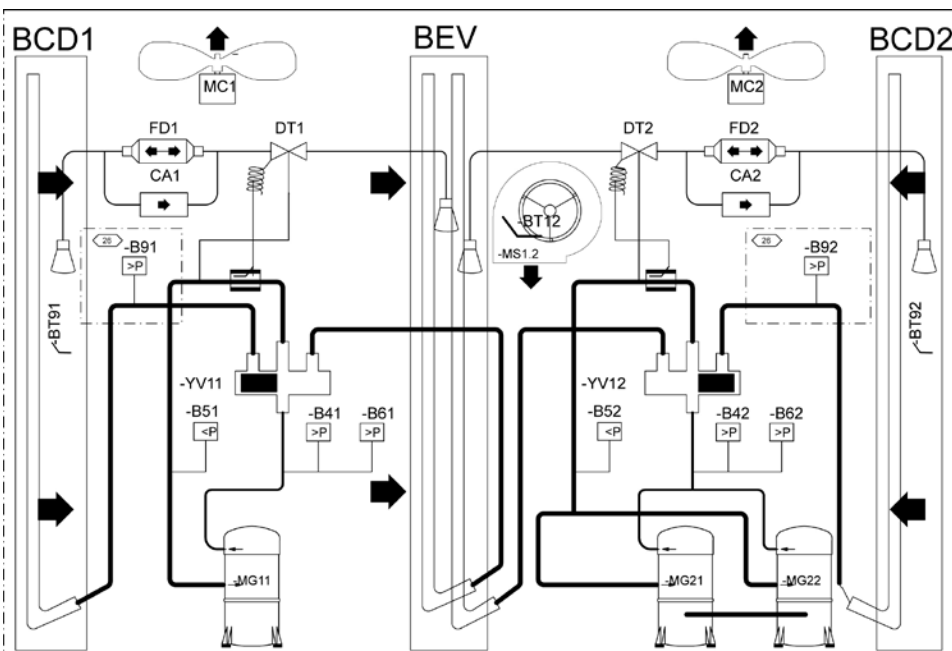

PRINCIPLE SKETCHES

BCD1.2	CONDENSER COIL	-B61-B62	COMPRESSOR -MG1-MG2 HIGH PRESSURE CONTROL SWITCH
BEC	HOT WATER COIL	-MC1-MC2	CONDENSER -MC1-MC2 FAN MOTOR
BEV	EVAPORATOR COIL	-MC3-MC4	CONDENSER -MC3-MC4 FAN MOTOR
CA1.2	CHECK VALVE	-MG11-MG12	COMPRESSOR -MG1-MG2
DT1.2	THERMOSTATIC EXPANSION VALVE	-MG21-MG22	COMPRESSOR -MG1-MG2
FD1.2	FILDER DRIER	-MS1-2	BLOWER FAN MOTOR -MS1
-B14-B15	HOT WATER BATTERY ANTIFREEZE THERMOSTAT	VAM1.2	MANUAL CHECK VALVE
-BT12	BLOWER TEMPERATURE PROBE	VRM	VANNE DE REGLAGE MANUELLE
-BT17	RETURN REGULATION TEMPERATURE SENSOR	-YV2	HOT WATER 3-WAY VALVE
-B41-B42	COMPRESSOR -MG1-MG2 HIGH PRESSURE SAFETY SWITCH	-YV11-YV12	COMPRESSOR -MG1-MG2 CYCLE REVERSAL VALVE
-B51-B52	COMPRESSOR -MG1-MG2 LOW PRESSURE SAFETY SWITCH		

FC 170

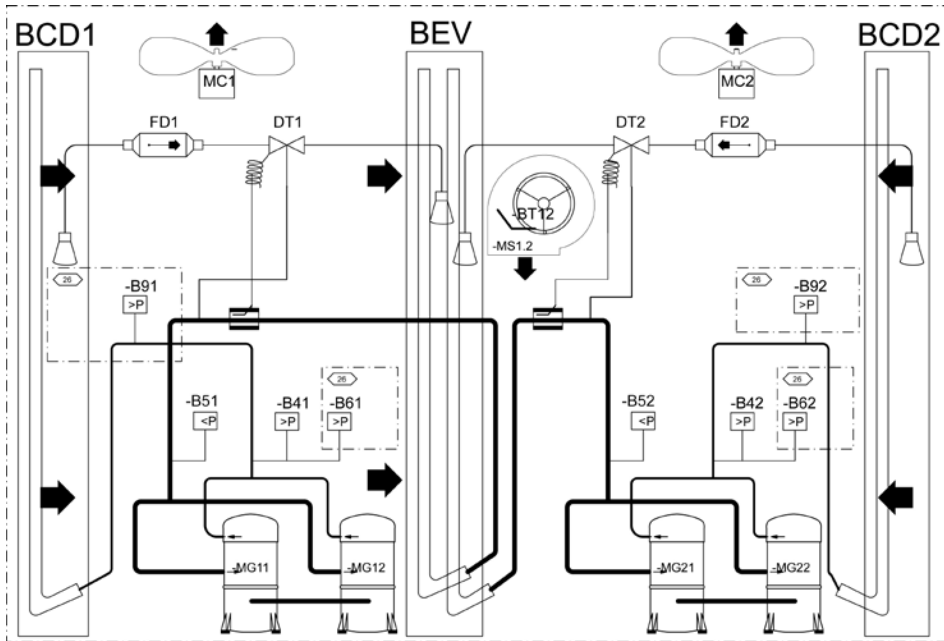

FH170

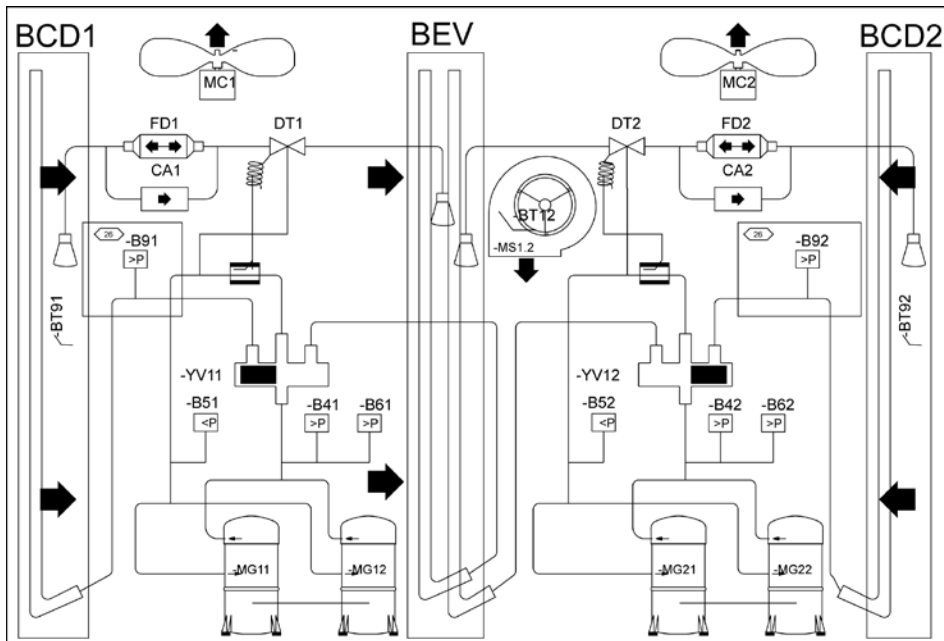

PRINCIPLE SKETCHES



BCD1.2	CONDENSER COIL	-B61-B62	COMPRESSOR -MG1-MG2 HIGH PRESSURE CONTROL SWITCH
BEC	HOT WATER COIL	-MC1-MC2	CONDENSER -MC1-MC2 FAN MOTOR
BEV	EVAPORATOR COIL	-MC3-MC4	CONDENSER -MC3-MC4 FAN MOTOR
CA1.2	CHECK VALVE	-MG11-MG12	COMPRESSOR -MG1-MG2
DT1.2	THERMOSTATIC EXPANSION VALVE	-MG21-MG22	COMPRESSOR -MG1-MG2
FD1.2	FILDER DRIER	-MS1-2	BLOWER FAN MOTOR -MS1
-B14-B15	HOT WATER BATTERY ANTIFREEZE THERMOSTAT	VAM1.2	MANUAL CHECK VALVE
-BT12	BLOWER TEMPERATURE PROBE	VRM	VANNE DE REGLAGE MANUELLE
-BT17	RETURN REGULATION TEMPERATURE SENSOR	-YV2	HOT WATER 3-WAY VALVE
-B41-B42	COMPRESSOR -MG1-MG2 HIGH PRESSURE SAFETY SWITCH	-YV11-YV12	COMPRESSOR -MG1-MG2 CYCLE REVERSAL VALVE
-B51-B52	COMPRESSOR -MG1-MG2 LOW PRESSURE SAFETY SWITCH		

FC 200 - 230

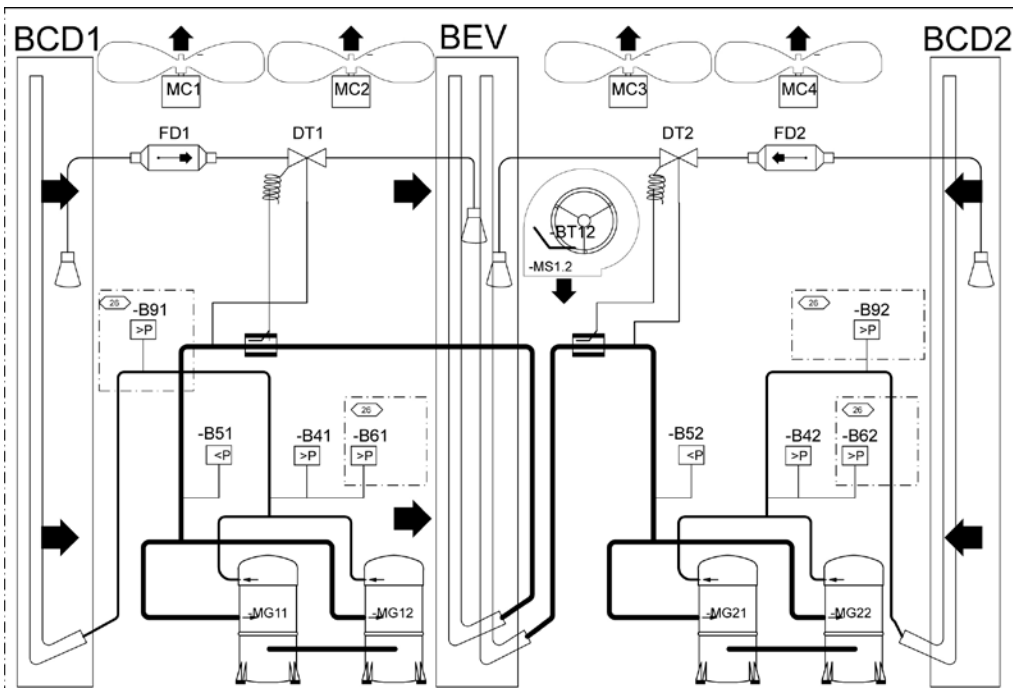

FH 200 - 230

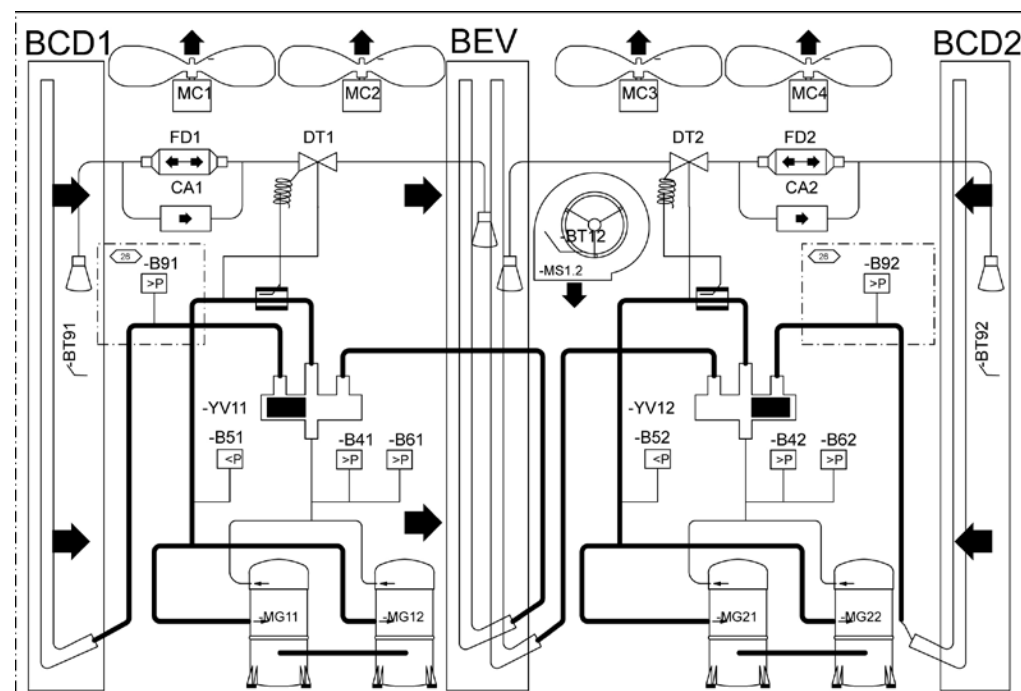

PRINCIPLE SKETCHES

UT	Air treatment unit	B41	Compressor -MG1 high pressure safety switch	FD	Dehumidifier filter
UF	Cooling unit	B42	Compressor -MG2 high pressure safety switch	MC1	Condenser -MC1 fan motor
BCD	Condenser coil	B51	Compressor -MG1 low pressure safety switch	MG1	Compressor -MG1 contactor
BEV1	Evaporator coil	DT	Thermostatic holder	MS1	Blower fan motor MS1
BT12	Blower temperature probe			VAM	Manual check valve
BTP1	Compressor -MG1 accumulator				

FX 025 e 030

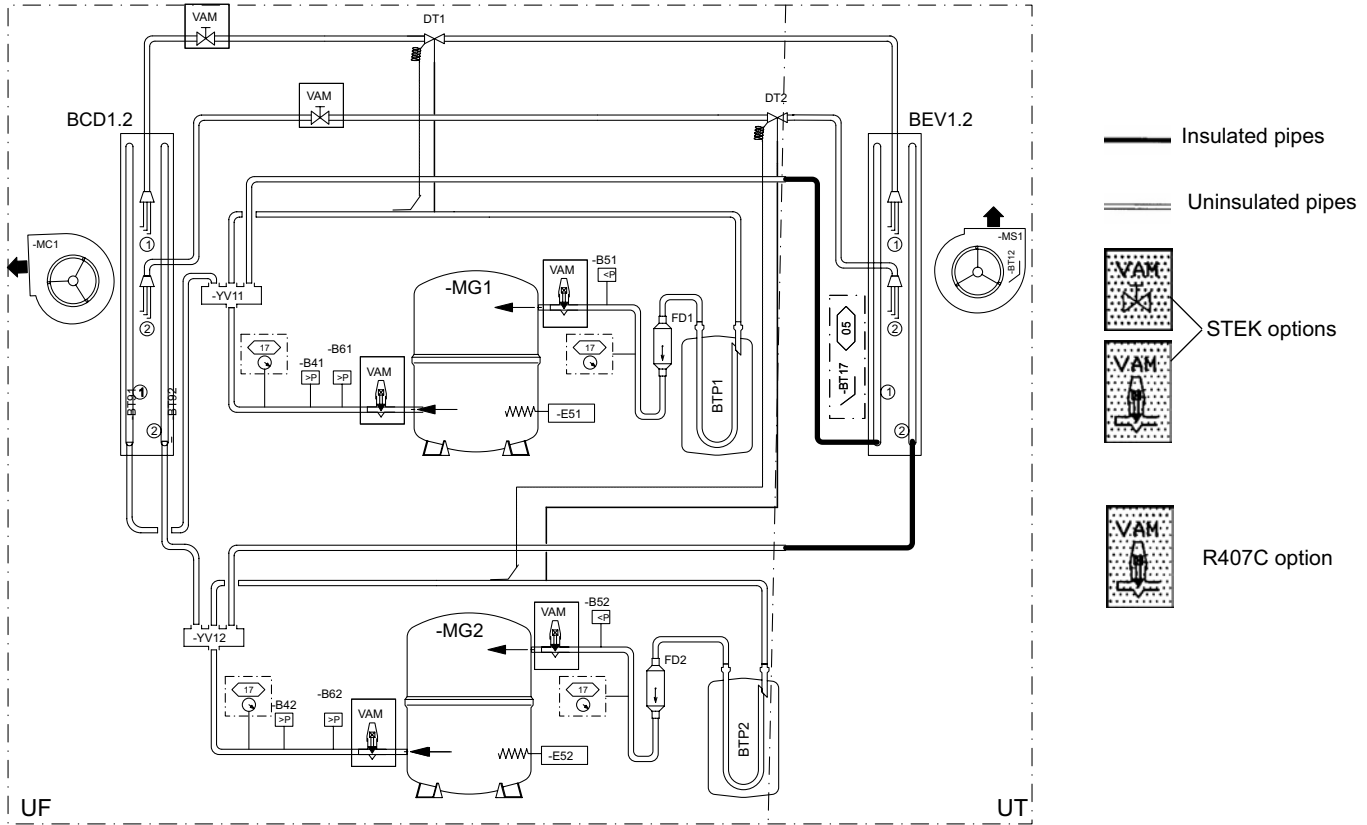

Pipe diameters

Discharge	3/4»
Suction	7/8»
Liquid line	5/8»

PRINCIPLE SKETCHES



UT	Air treatment unit	B41	Compressor -MG1 high pressure safety switch	FD	Dehumidifier filter
UF	Cooling unit	B42	Compressor -MG2 high pressure safety switch	MC1	Condenser -MC1 fan motor
BCD	Condenser coil	B51	Compressor -MG1 low pressure safety switch	MG1	Compressor -MG1 contactor
BEV1	Evaporator coil	DT	Thermostatic holder	MS1	Blower fan motor MS1
BT12	Blower temperature probe			VAM	Manual check valve
BTP1	Compressor -MG1 accumulator				

FX da 035 a 085

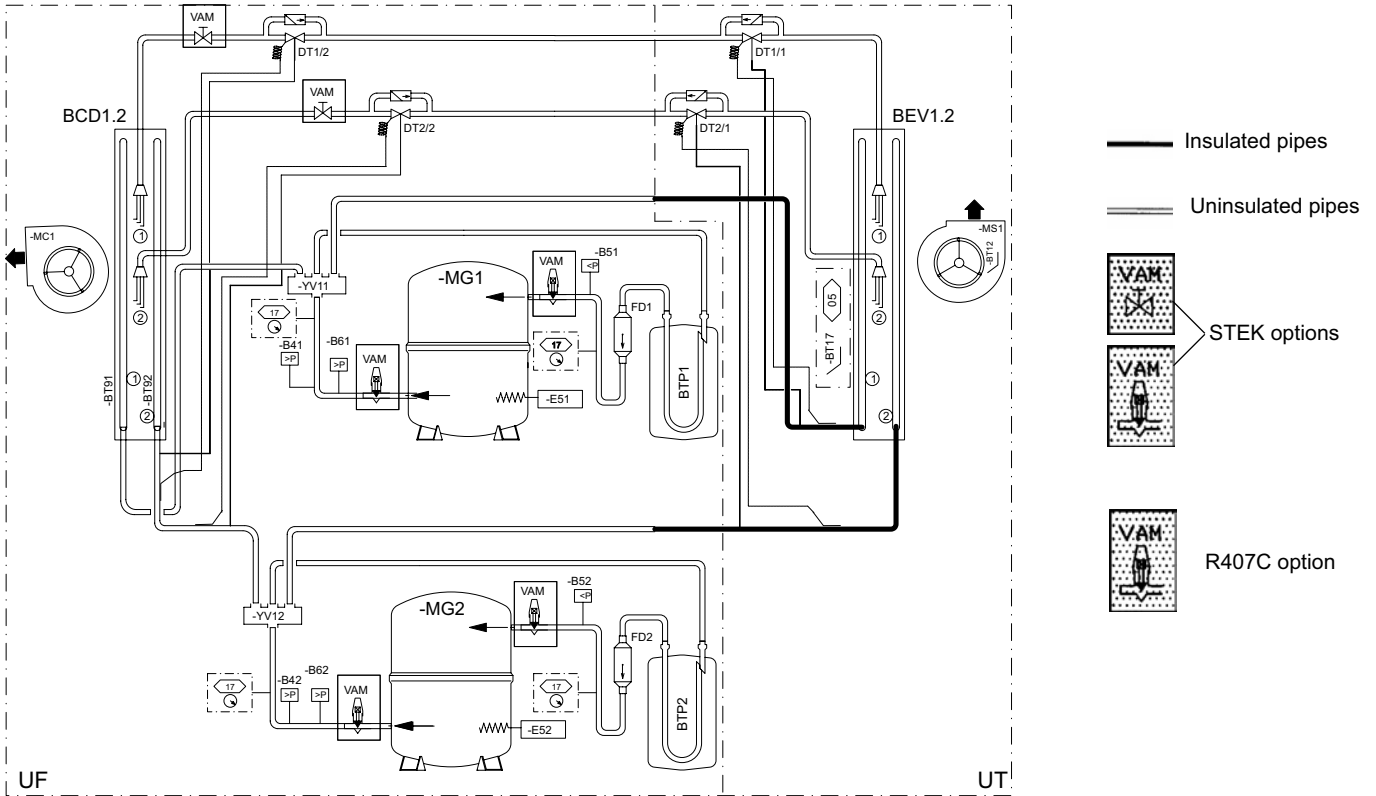

Pipe diameters

	FX 035-040	FX 055-085
Discharge	3/4»	7/8»
Suction	7/8»	1» 1/8
Liquid line	5/8»	5/8»

PRINCIPLE SKETCHES

UT	Air treatment unit	B41	Compressor -MG1 high pressure safety switch	FD	Dehumidifier filter
UF	Cooling unit	B42	Compressor -MG2 high pressure safety switch	MC1	Condenser -MC1 fan motor
BCD	Condenser coil	B51	Compressor -MG1 low pressure safety switch	MG1	Compressor -MG1 contactor
BEV1	Evaporator coil	DT	Thermostatic holder	MS1	Blower fan motor MS1
BT12	Blower temperature probe			VAM	Manual check valve
BTP1	Compressor -MG1 accumulator				

FX 100

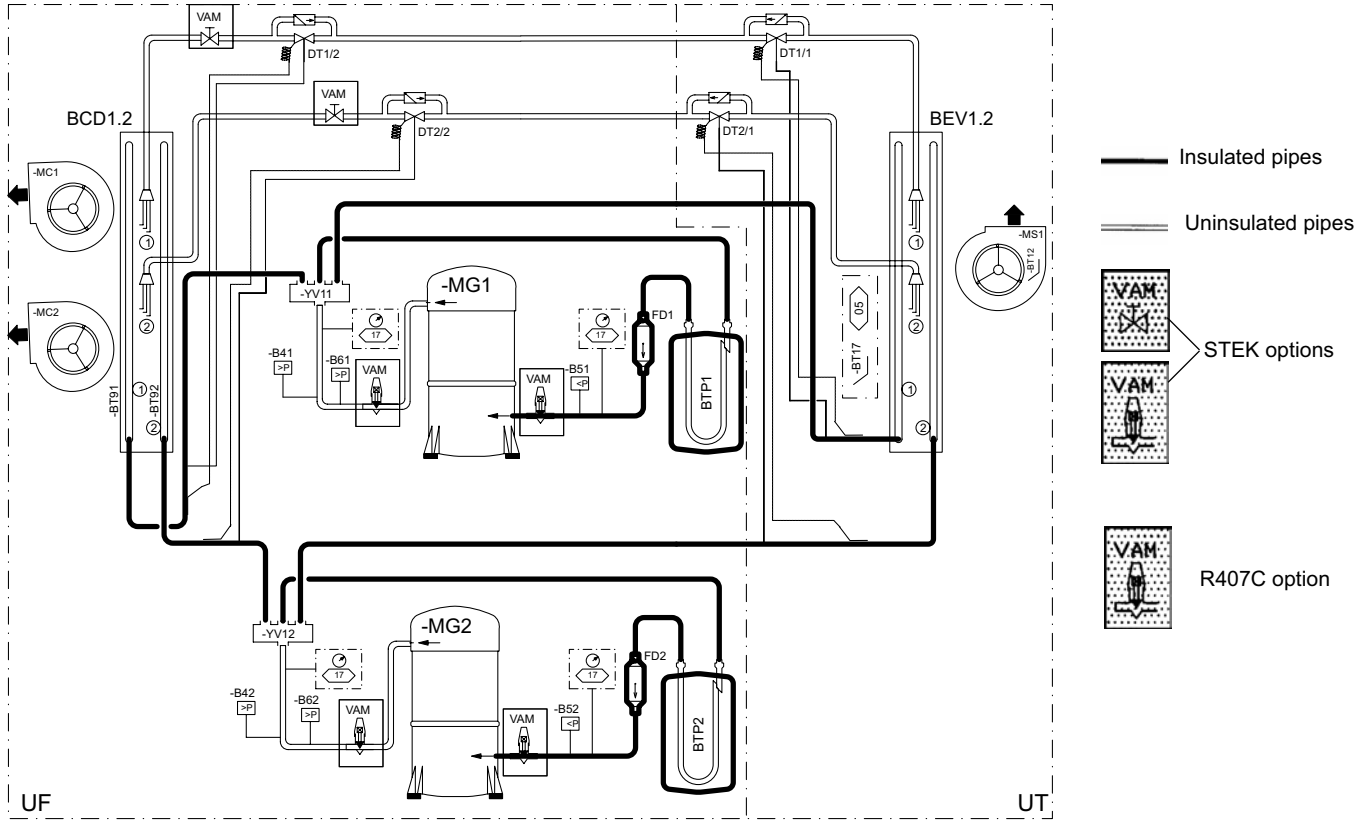

Pipe diameters

Discharge	7/8»
Suction	1»3/8
Liquid line	7/8»

PRINCIPLE SKETCHES



UT	Air treatment unit	B41	Compressor -MG1 high pressure safety switch	FD	Dehumidifier filter
UF	Cooling unit	B42	Compressor -MG2 high pressure safety switch	MC1	Condenser -MC1 fan motor
BCD	Condenser coil	B51	Compressor -MG1 low pressure safety switch	MG1	Compressor -MG1 contactor
BEV1	Evaporator coil	DT	Thermostatic holder	MS1	Blower fan motor MS1
BT12	Blower temperature probe			VAM	Manual check valve
BTP1	Compressor -MG1 accumulator				

FX 110 - FX 140 - FX 170

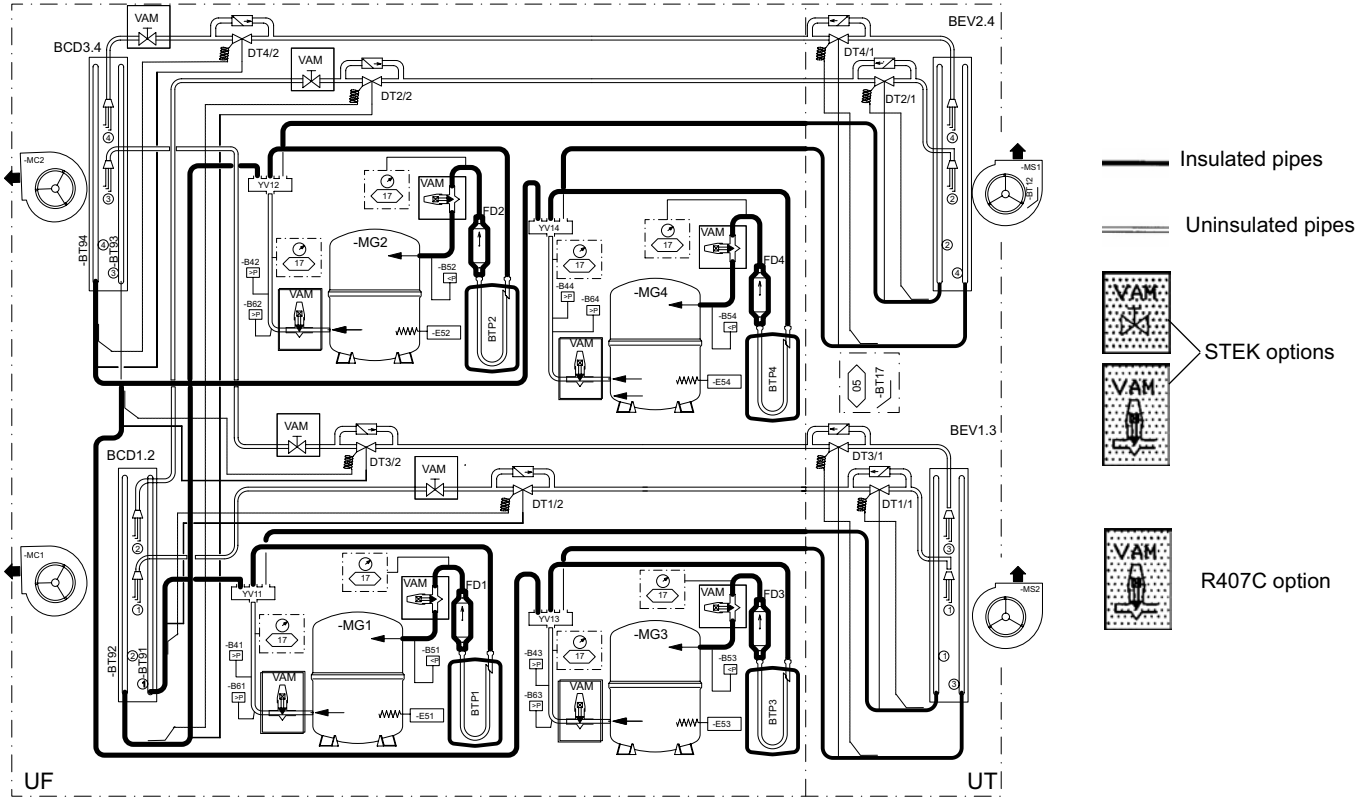

Pipe diameters

Discharge	7/8»
Suction	1»1/8
Liquid line	5/8»

HYDROLIC PRINCIPLE SKETCHES

(HOT WATER COIL)

UT Air treatment unit	B41 Compressor -MG1 high pressure safety switch	FD Dehumidifier filter
UF Cooling unit	B42 Compressor -MG2 high pressure safety switch	MC1 Condenser -MC1 fan motor
BCD Condenser coil	B51 Compressor -MG1 low pressure safety switch	MG1 Compressor -MG1 contactor
BEV1 Evaporator coil	DT Thermostatic holder	MS1 Blower fan motor MS1
BT12 Blower temperature probe		VAM Manual check valve
BTP1 Compressor -MG1 accumulator		

da F085 a F190 e da FX025 a FX170

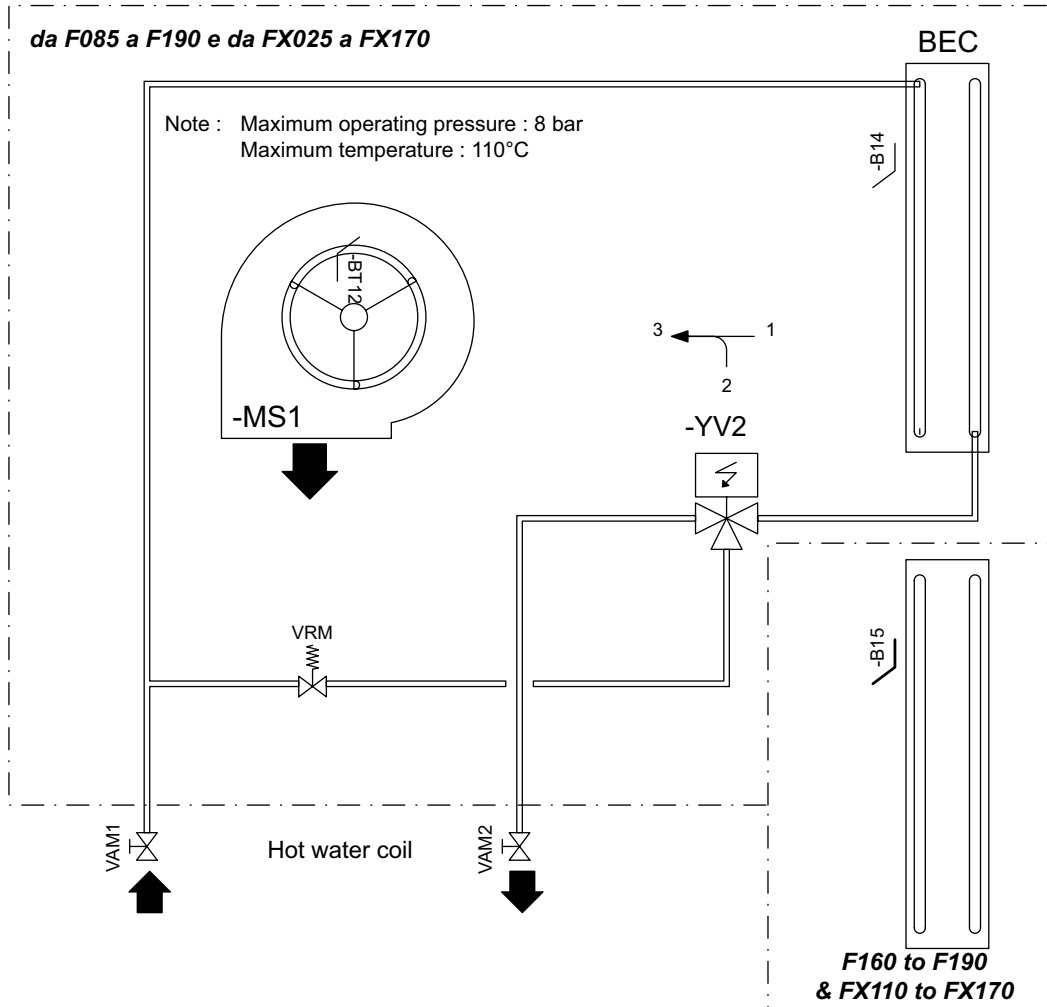

Pipe diameters (DN)

	1 row	2 rows
F085	25	32
F100	25	32
F120	25	32
F150	25	40
F170	25	40
F200	25	40
F230	25	40
FX025	20	20
FX030	20	20
FX035	20	20
FX040	20	20
FX055	20	25
FX070	20	25
FX085	20	25
FX100	25	25
FX110	25	32
FX140	25	32
FX170	25	32

FC/FH FG/FD	85/100/120 150/170
------------------------	-------------------------------

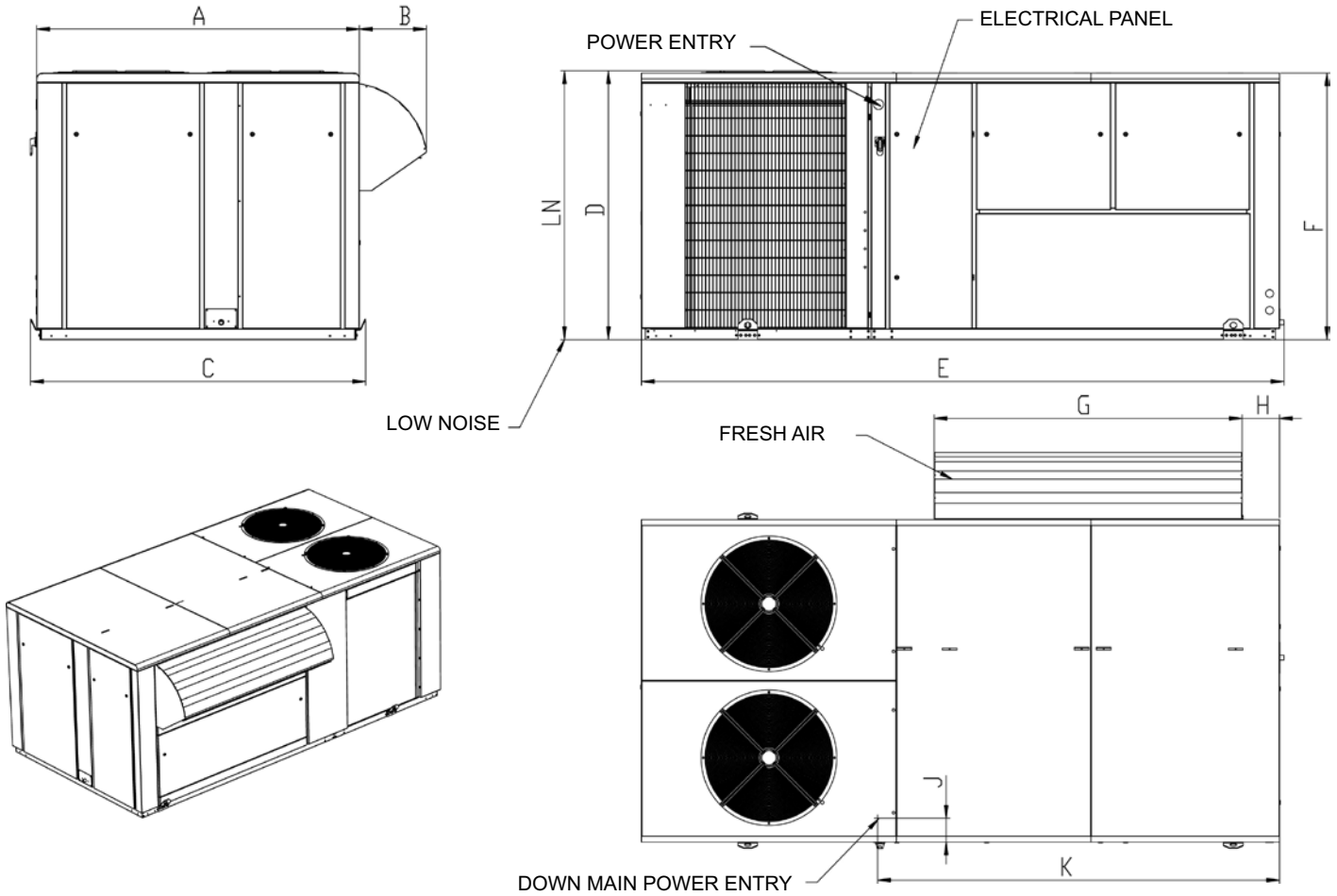

DIMENSIONS											
	A	B	C	D	E	F	G	H	J	K	LN
85-100-120	2200	360	2285	1510	3350	1500	1915	150	165	2222	1776
150-170	2200	450	2285	1834	4380	1820	2100	255	165	2740	2095

FC/FH FG/FD	200/230
----------------	---------

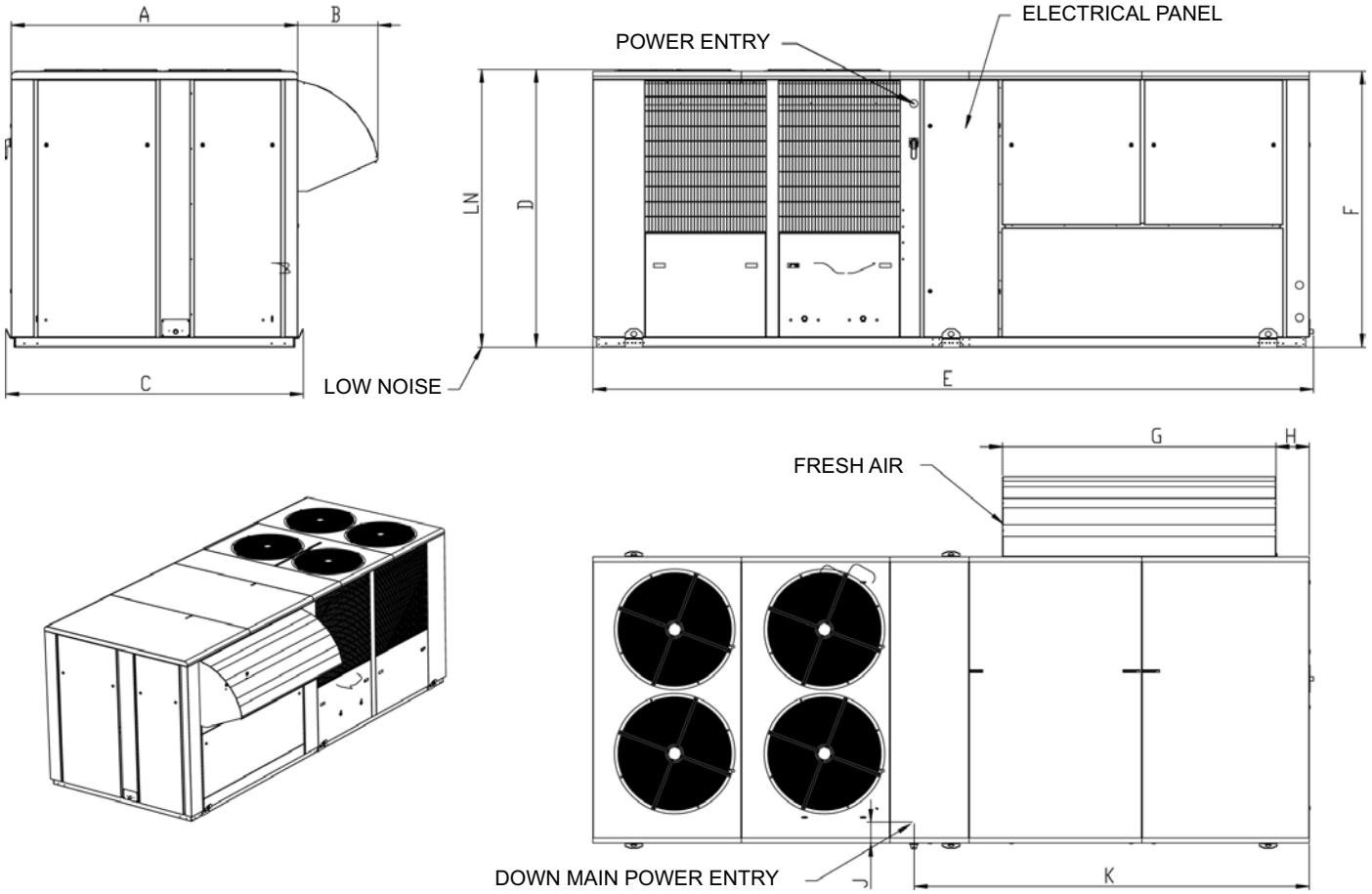

DIMENSIONS

	A	B	C	D	E	F	G	H	J	K	LN
200-230	2200	615	2285	2134	5533	2120	2100	255	165	3033	2395

FC/FH FG/FD	85/100/120 150/170
------------------------	-------------------------------

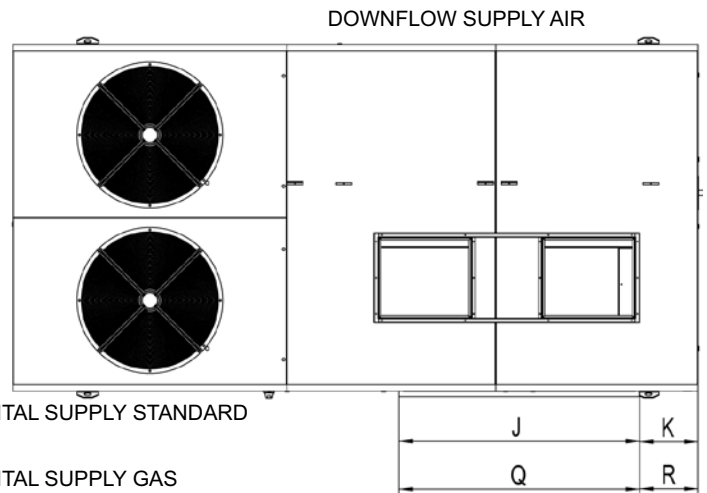
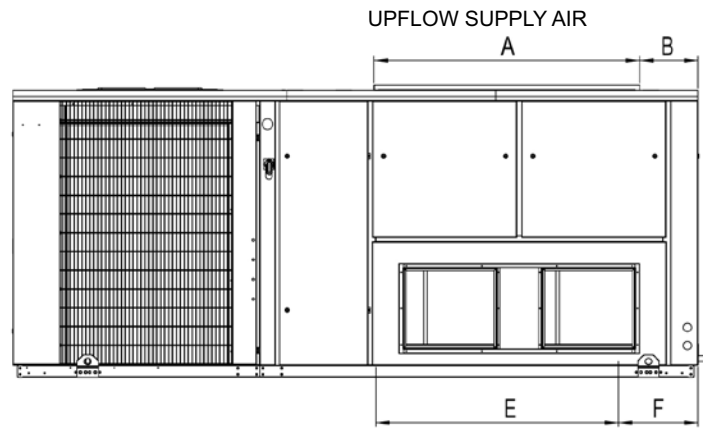
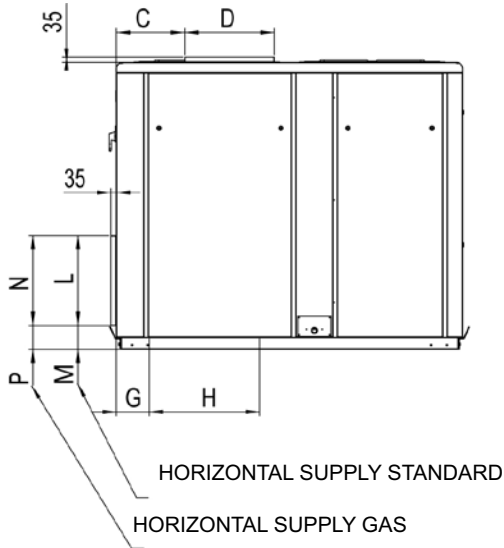

SUPPLY																
	A	B	C	D	E	F	G	H	J	K	L	M	N	P	Q	R
85-100-120	1355	385	260	495	1430	410	210	700	1355	160	495	155	500	155	1090	410
150-170	1690	370	435	570	1540	505	210	700	1530	370	570	150	535	135	1440	545
AIRFLOW CONFIGURATION	UPFLOW SUPPLY				DOWNFLOW SUPPLY				HORIZONTAL SUPPLY				GAS SUPPLY			

FC/FH FG/FD	200-230
------------------------	----------------

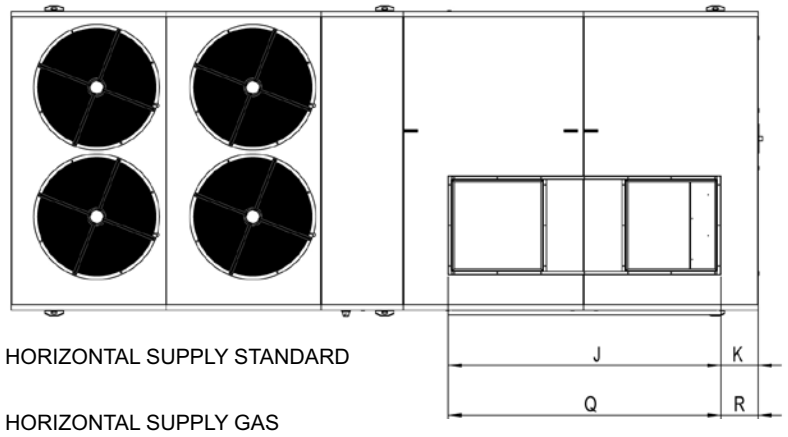
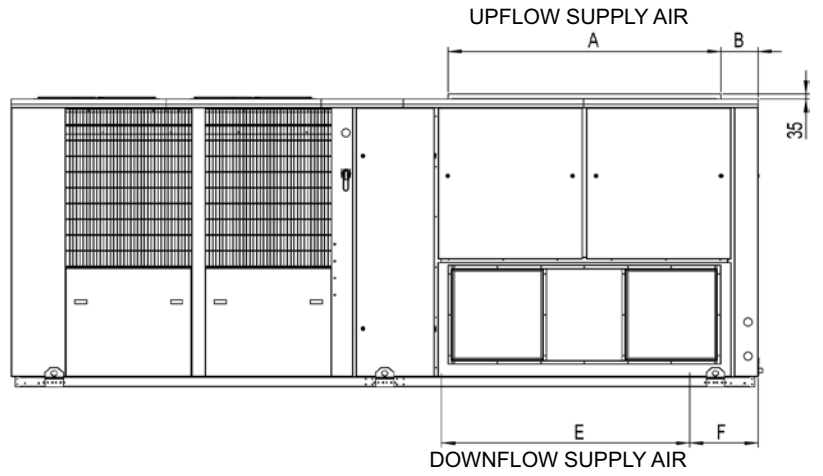
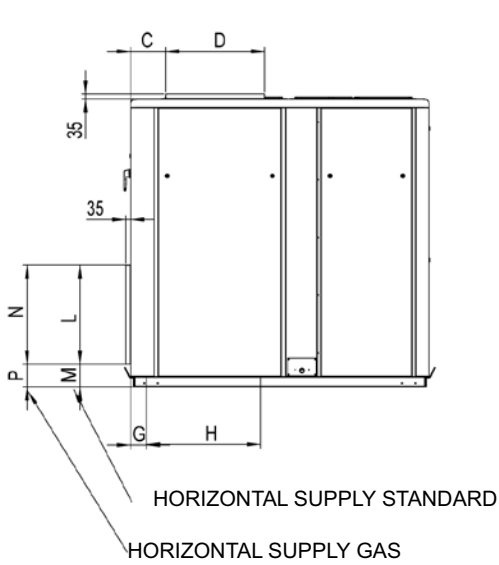

SUPPLY																
	A	B	C	D	E	F	G	H	J	K	L	M	N	P	Q	R
200-230	2010	275	260	730	1827	505	120	840	2010	275	730	165	700	165	1700	500
AIRFLOW CONFIGURATION	UPFLOW SUPPLY				DOWNFLOW SUPPLY				HORIZONTAL SUPPLY				GAS SUPPLY			

FC/FH FG/FD	85/100/120 150/170
------------------------------	-------------------------------------

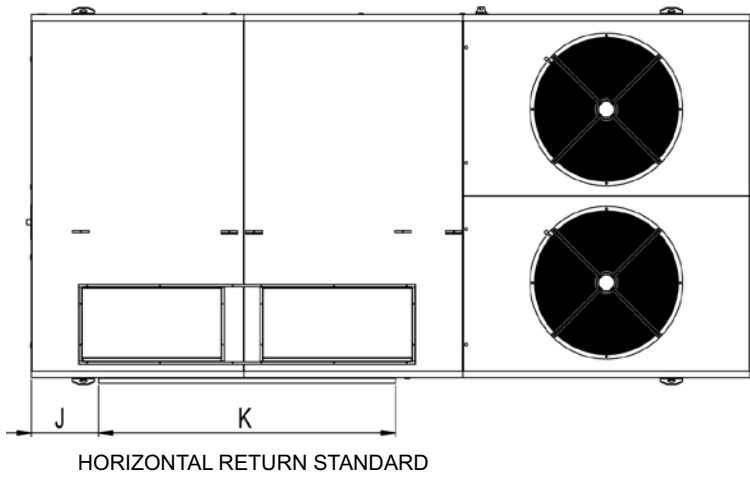
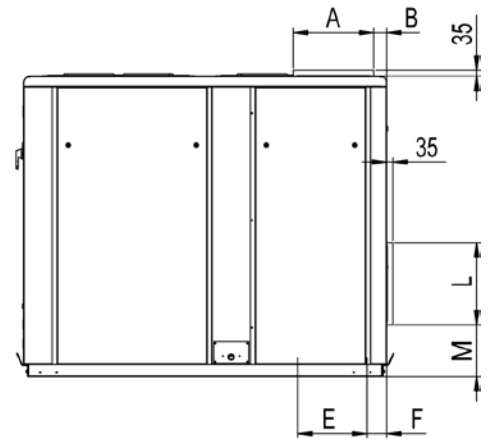
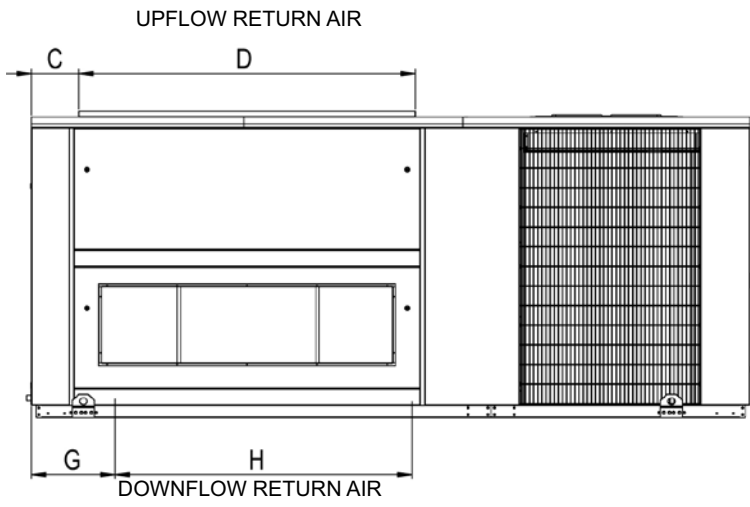

RETURN												
	A	B	C	D	E	F	G	H	J	K	L	M
85-100-120	460	81	165	1790	420	120	200	1750	210	1790	460	185
150-170	490	80	287	2040	420	120	305	2000	405	1800	500	310
AIRFLOW CONFIGURATION	UPFLOW RETURN			DOWNFLOW RETURN				HORIZONTAL RETURN				

FC/FH FG/FD	200-230
------------------------	----------------

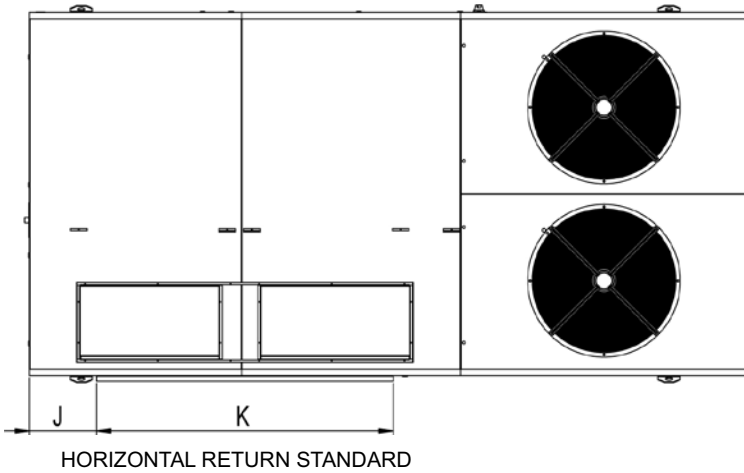
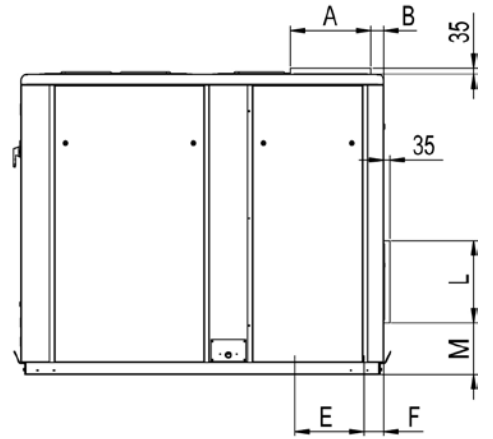
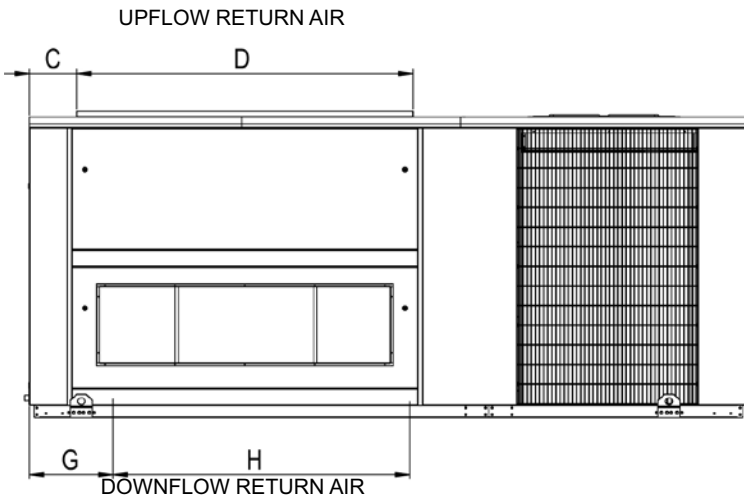

RETURN												
	A	B	C	D	E	F	G	H	J	K	L	M
200-230	490	80	287	2040	420	120	305	2000	405	1800	700	305
AIRLOW CONFIGURATION	UPFLOW RETURN			DOWNFLOW RETURN				HORIZONTAL RETURN				

**FC/FH
FG/FD** **ALL SIZES**

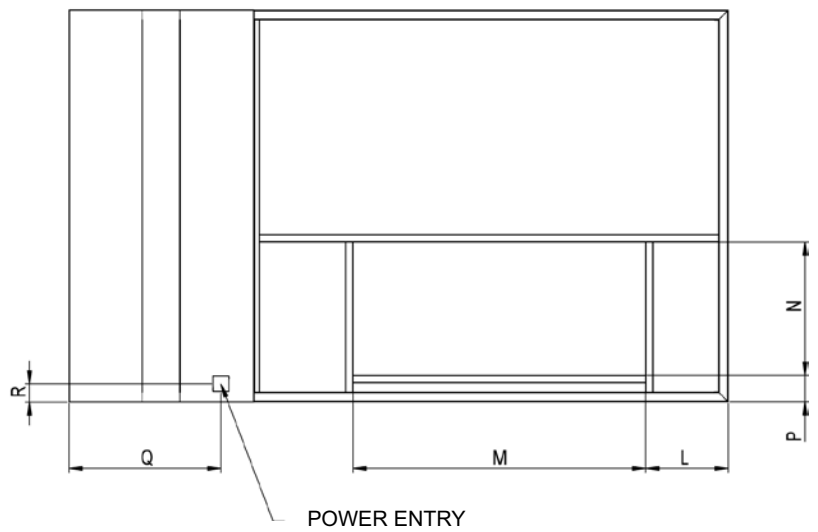
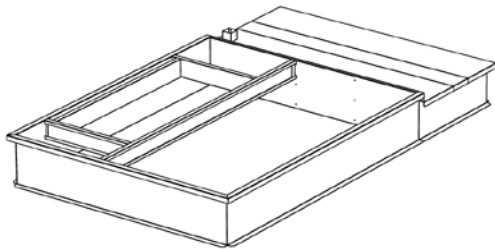
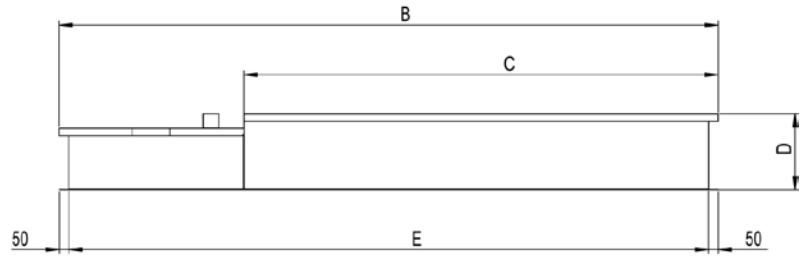
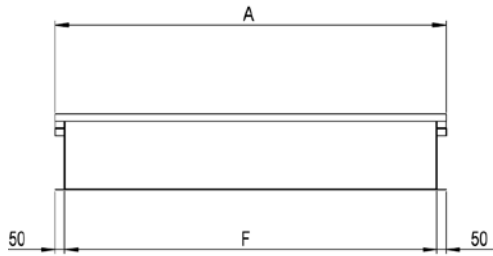

NON ADJUSTABLE ROOFTOP												
	A	B	C	D	E	F	L	M	N	P	Q	R
85-100-120	2056	2770	2005	400	2672	1959	336	1433	700	139	614	90
150-170	2056	3466	2493	400	3367	1959	433	1540	700	139	800	90
200-230	2056	4066	2493	425	3967	1959	432	1830	800	89	1095	105

**FC/FH
FG/FD** **ALL SIZES**

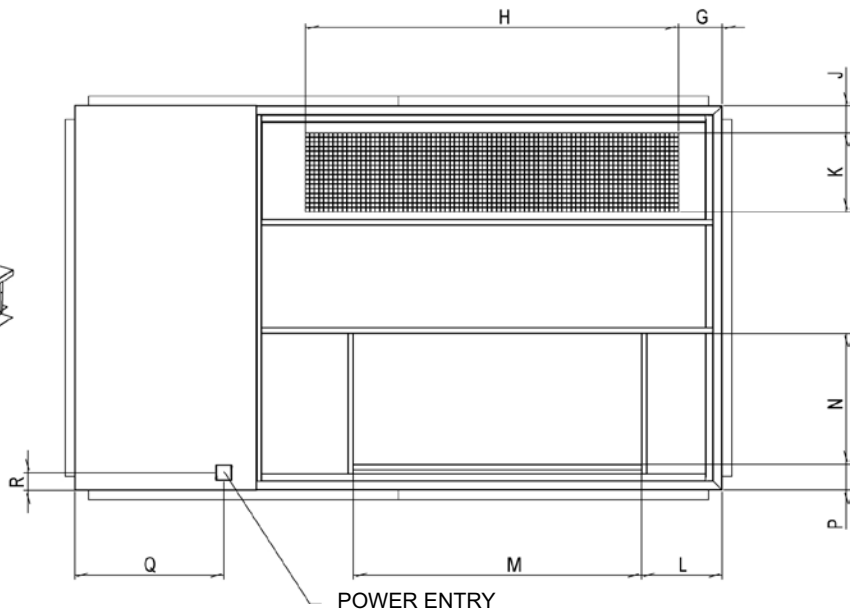
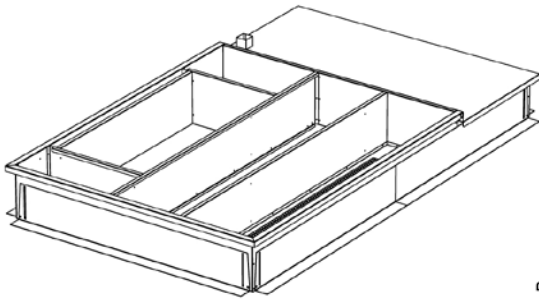
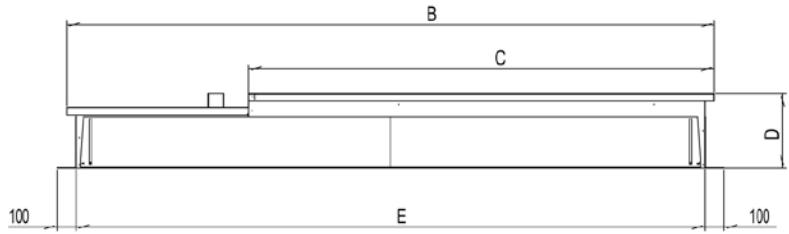
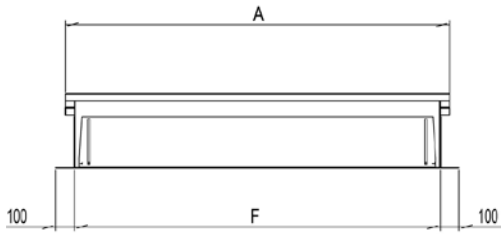

ADJUSTABLE ROOFCURB																
	A	B	C	D	E	F	G	H	J	K	L	M	N	P	Q	R
85-100-120	2056	2771	2005	400	2672	1959	130	1747	145	420	325	1433	700	140	615	105
150-170	2056	3466	2493	400	3368	1959	235	1997	145	420	430	1540	700	140	800	105
200-230	2056	4066	2493	400	3968	1959	235	1997	145	420	430	1830	800	89	1105	105

**FC/FH
FG/FD** **ALL SIZES**

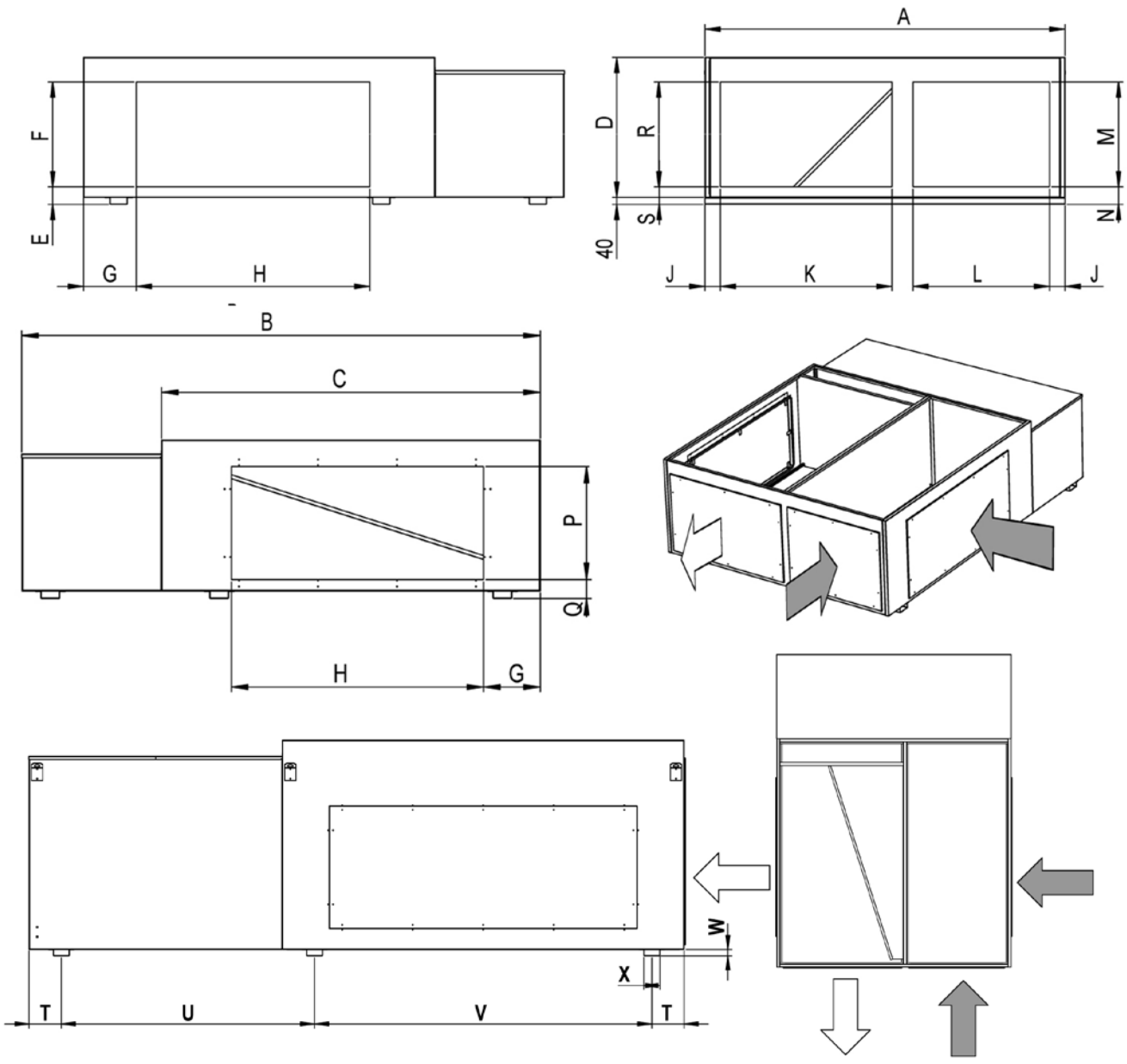

MULTIDIRECTIONAL ROOFCURB											
	A	B	C	D	E	F	G	H	J	K	L
85-100-120	2056	2745	2005	800	100	600	300	1335	88	980	780
50-170	2056	3441	2493	1100	100	600	230	1540	88	980	780
200-230	2056	4070	2493	1300	200	700	322	1850	88	980	780

MULTIDIRECTIONAL ROOFCURB											
	M	N	P	Q	R	S	T	U	V	W	X
85-100-120	600	100	600	100	600	100	200	794	1550	40	100
50-170	900	100	600	100	900	100	200	1241	1798	40	100
200-230	1100	100	600	100	1100	100	200	1571	2093	40	100

**FC/FH
FG/FD** **ALL SIZES**

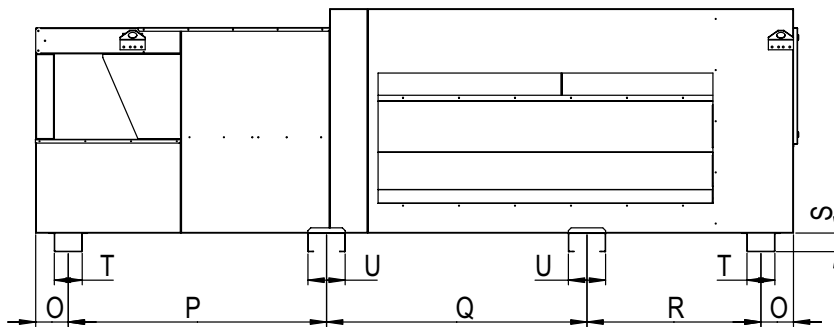
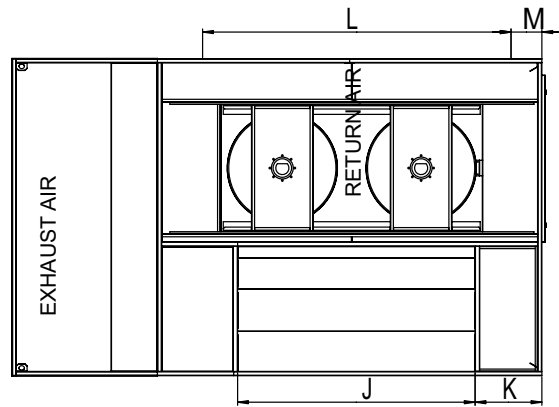
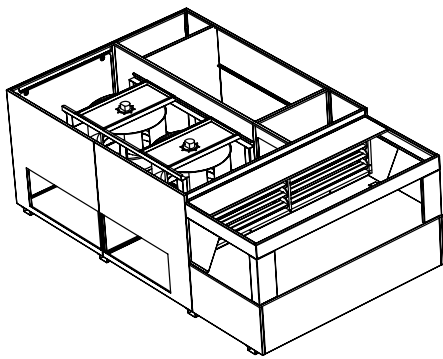
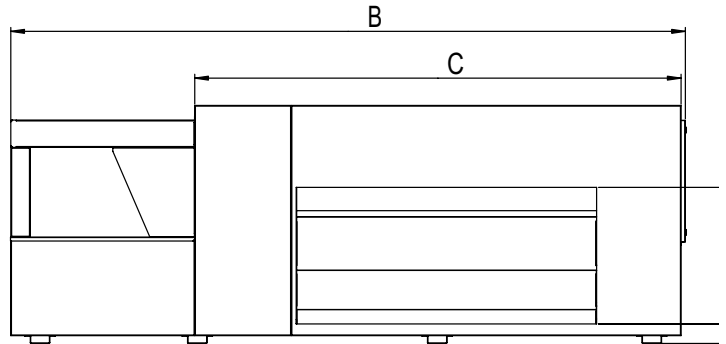
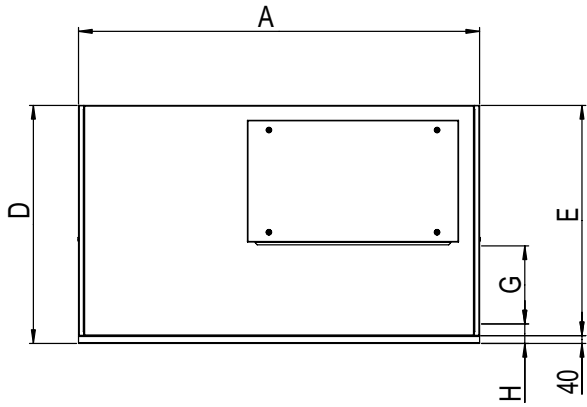

HORIZONTAL RETURN ROOFCURB										
	A	B	C	D	E	G	H	J	K	L
85-100-120	2056	2762	2005	1220	1180	400	100	1440	325	1600
150-170	2056	3460	2493	1220	1180	400	100	1540	433	2000
200-230	2056	4096	2493	1305	1205	400	150	1800	433	2300

HORIZONTAL RETURN ROOFCURB									
	M	N	O	P	Q	R	S	T	U
85-100-120	200	100	150	585	1002	853	40	100	100
150-170	200	100	150	793	1246	1097	40	100	100
200-230	100	150	175	1388	1400	935	100	150	200

**FC/FH
FG/FD** **ALL SIZES**

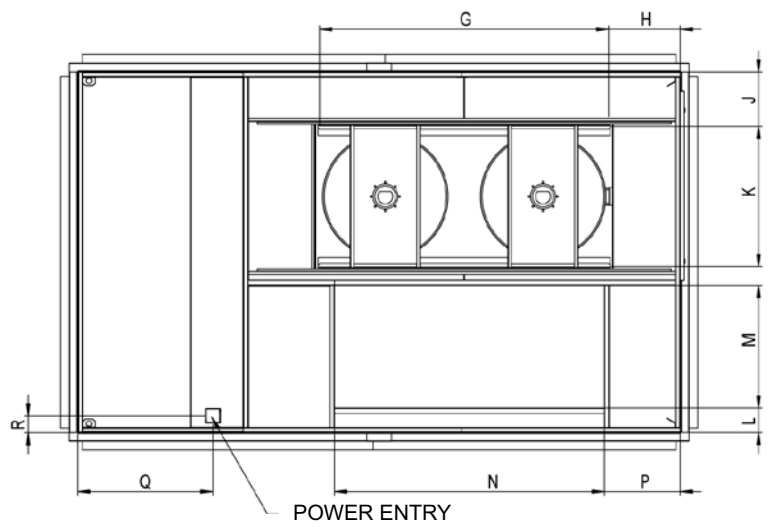
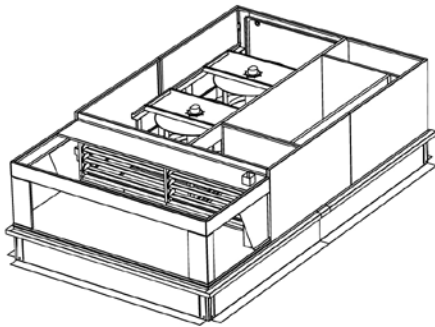
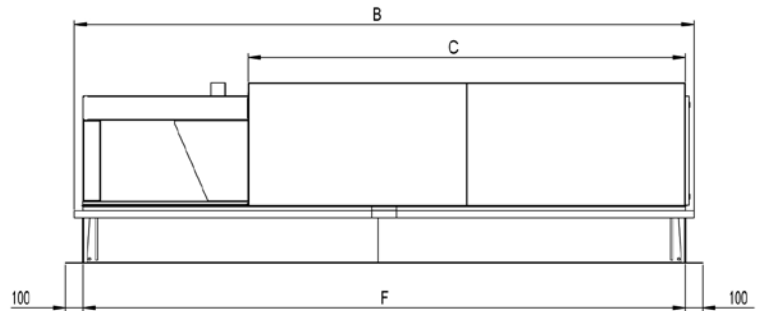
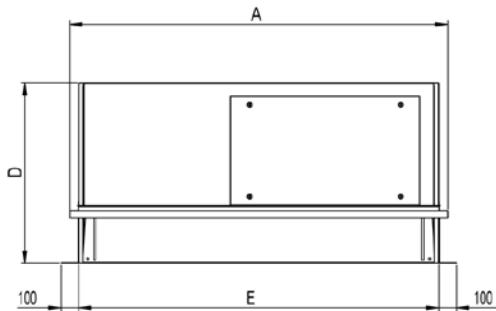

RETURN ROOFCURB																
	A	B	C	D	E	F	G	H	J	K	L	M	N	P	Q	R
85-100-120	2156	2840	2005	1030	2056	2740	1650	178	270	840	140	700	1440	327	580	95
150-170	2158	3536	2493	1030	2056	3436	1650	410	270	840	140	700	1540	433	770	95
200-230	2158	4174	2493	1055	2056	4074	2100	198	309	700	58	680	1830	433	1113	80

**FC/FH
FG/FD** **ALL SIZES**

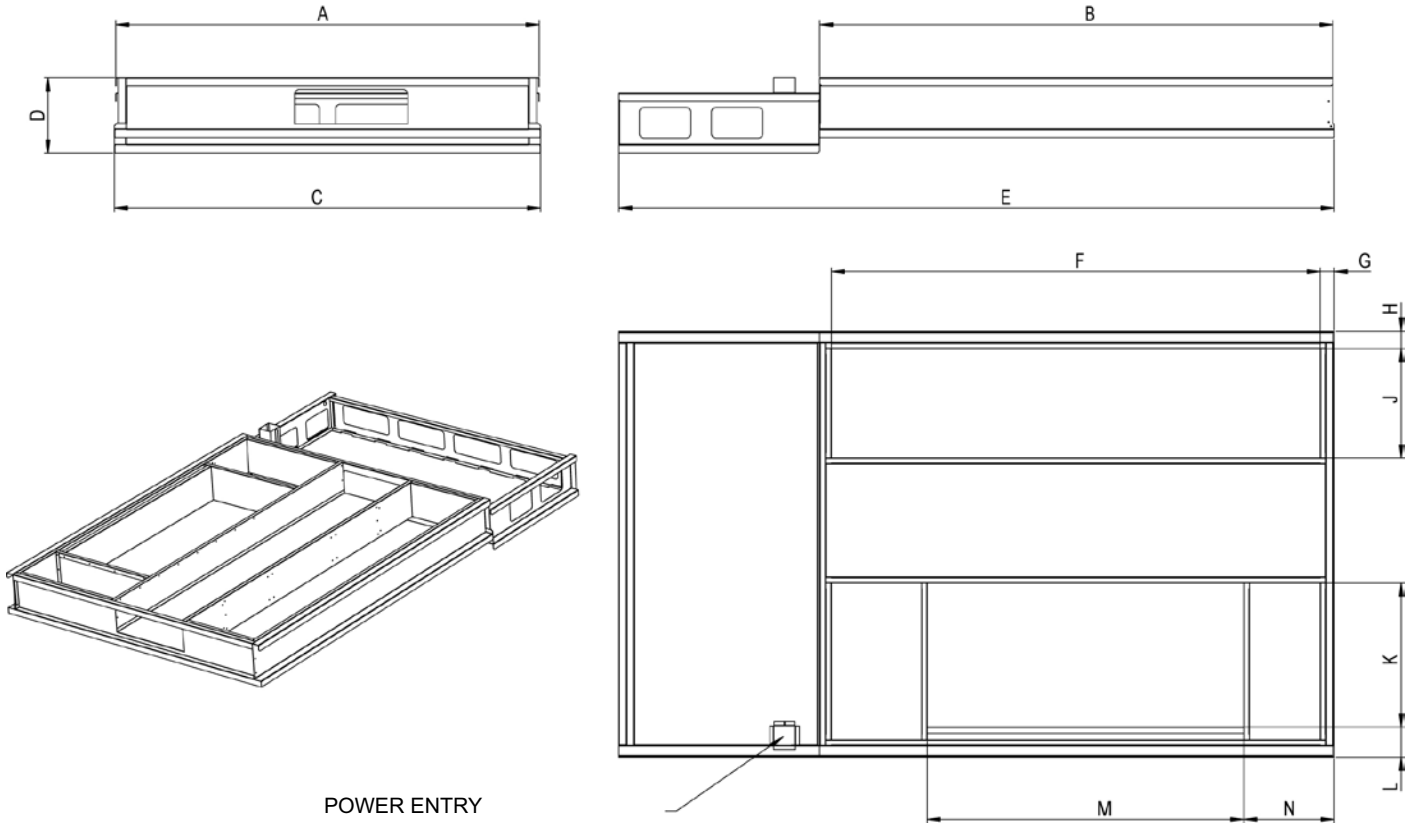

TRANSITIONB ROOFCURB													
	A	B	C	D	E	F	G	H	J	K	L	M	N
85-100-120	2059	2008	2072	365	2833	1889	74	85	532	700	147	1443	325
150-170	2059	2496	2072	365	3529	2377	74	85	532	700	147	1540	434
200-230	2059	2496	2072	415	4125	2377	74	85	532	812	85	1830	440

FXK = Heat recovery unit

FXK
25/30

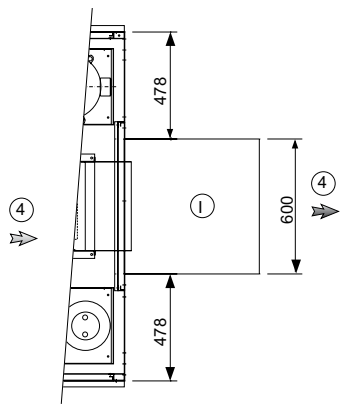
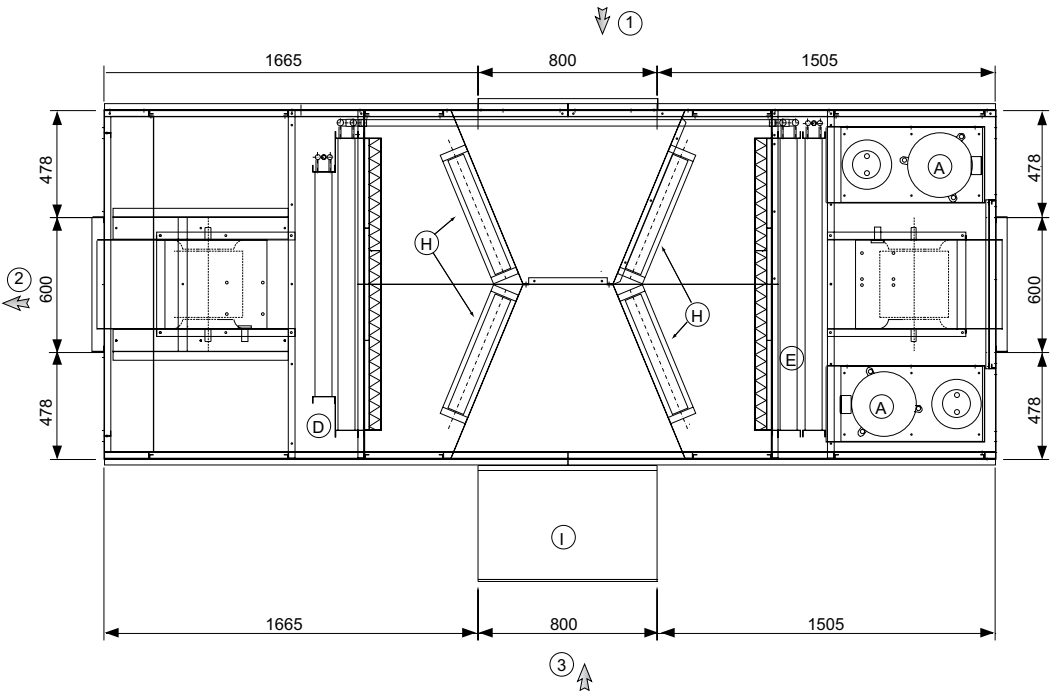
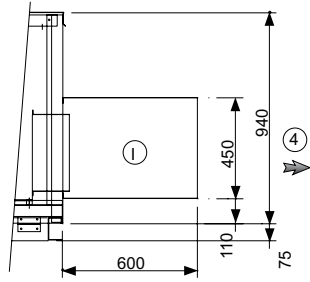
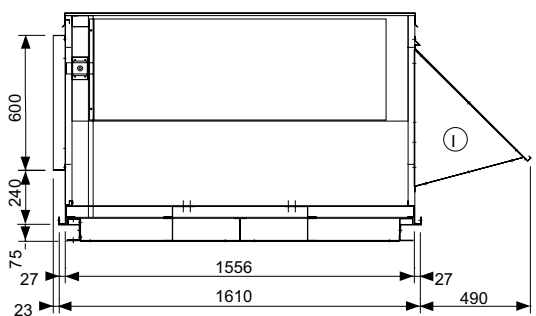
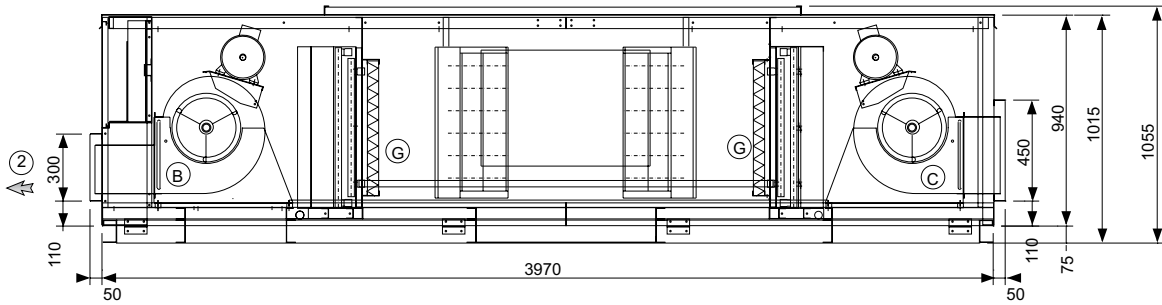

A	Compressor	1	Return air
B	Supply fan	2	Supply air
C	Exhaust fan	3	Fresh air
D	Evaporator coil	4	Exhaust air
E	Condenser coil	5	Flue outlet
F	Control box	6	Power entry
G	Filter	7	Gas entry
H	Damper	8	Condensate drain
I	Air hood		

FXK = Heat recovery unit

FXK 35/40/55

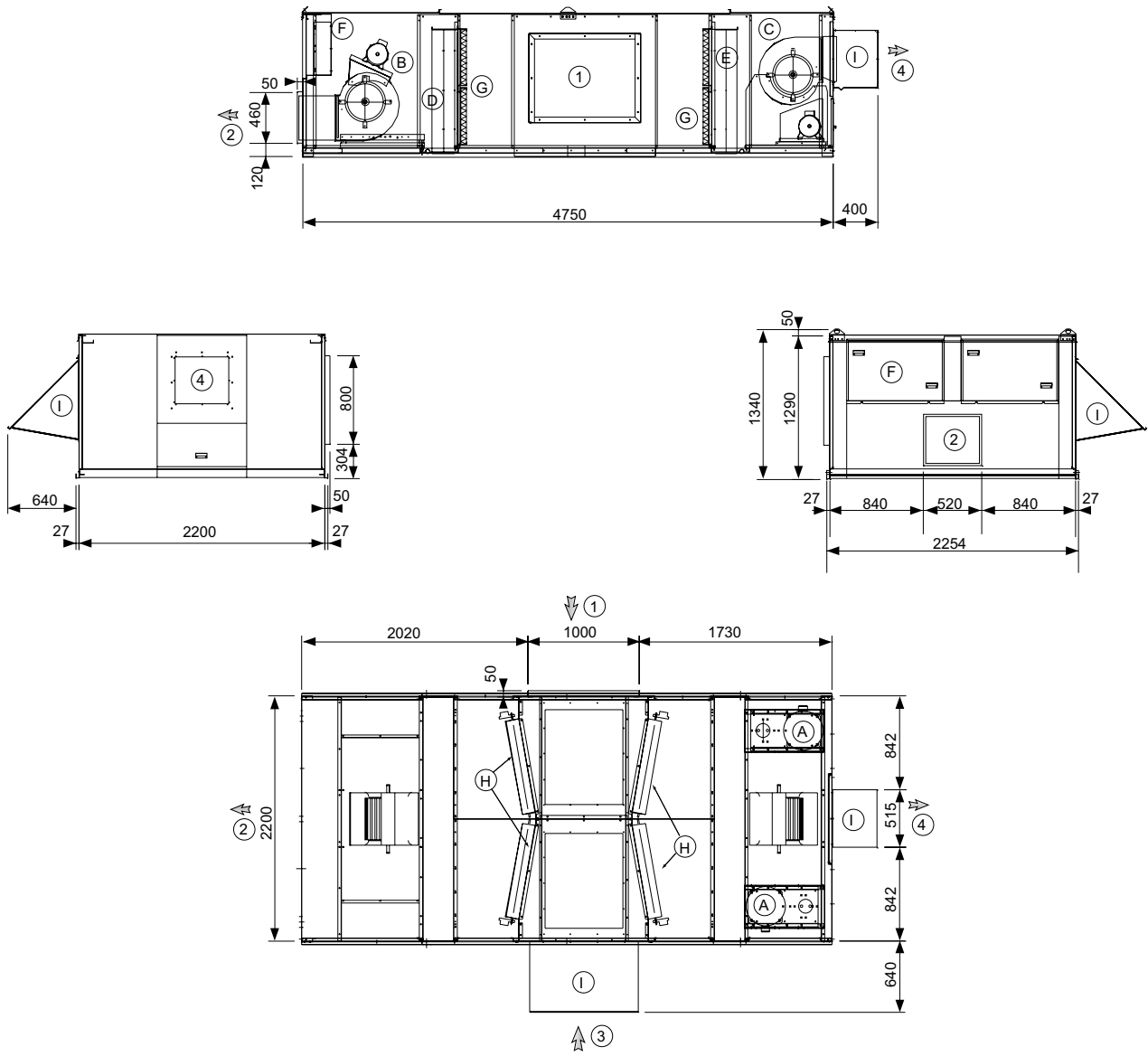

A	Compressor	1	Return air
B	Supply fan	2	Supply air
C	Exhaust fan	3	Fresh air
D	Evaporator coil	4	Exhaust air
E	Condenser coil	5	Flue outlet
F	Control box	6	Power entry
G	Filter	7	Gas entry
H	Damper	8	Condensate drain
I	Air hood		

FXK = Heat recovery unit

FXK
70/85

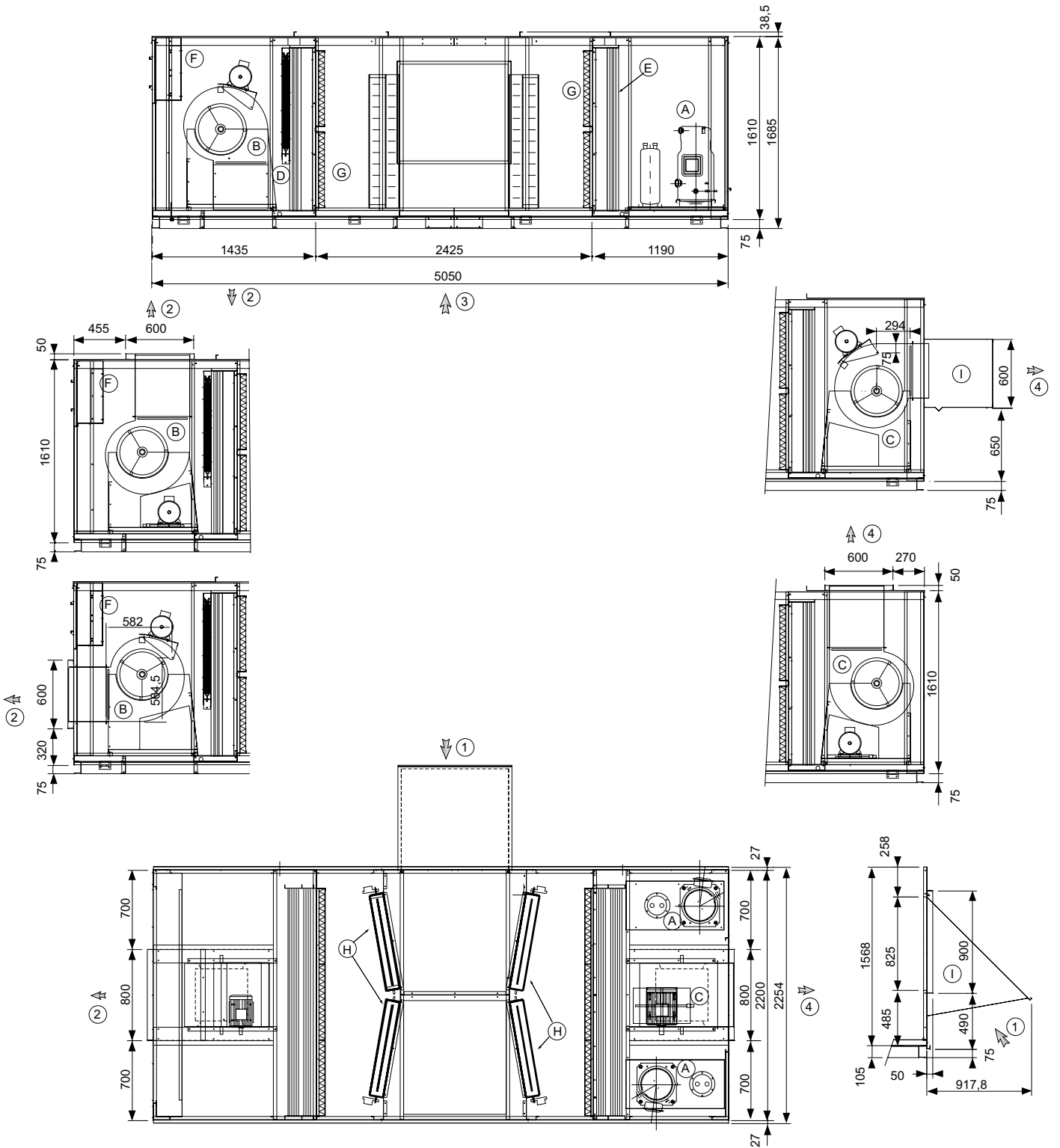

A	Compressor	1	Return air
B	Supply fan	2	Supply air
C	Exhaust fan	3	Fresh air
D	Evaporator coil	4	Exhaust air
E	Condenser coil	5	Flue outlet
F	Control box	6	Power entry
G	Filter	7	Gas entry
H	Damper	8	Condensate drain
I	Air hood		

FXK = Heat recovery unit

FXK 100

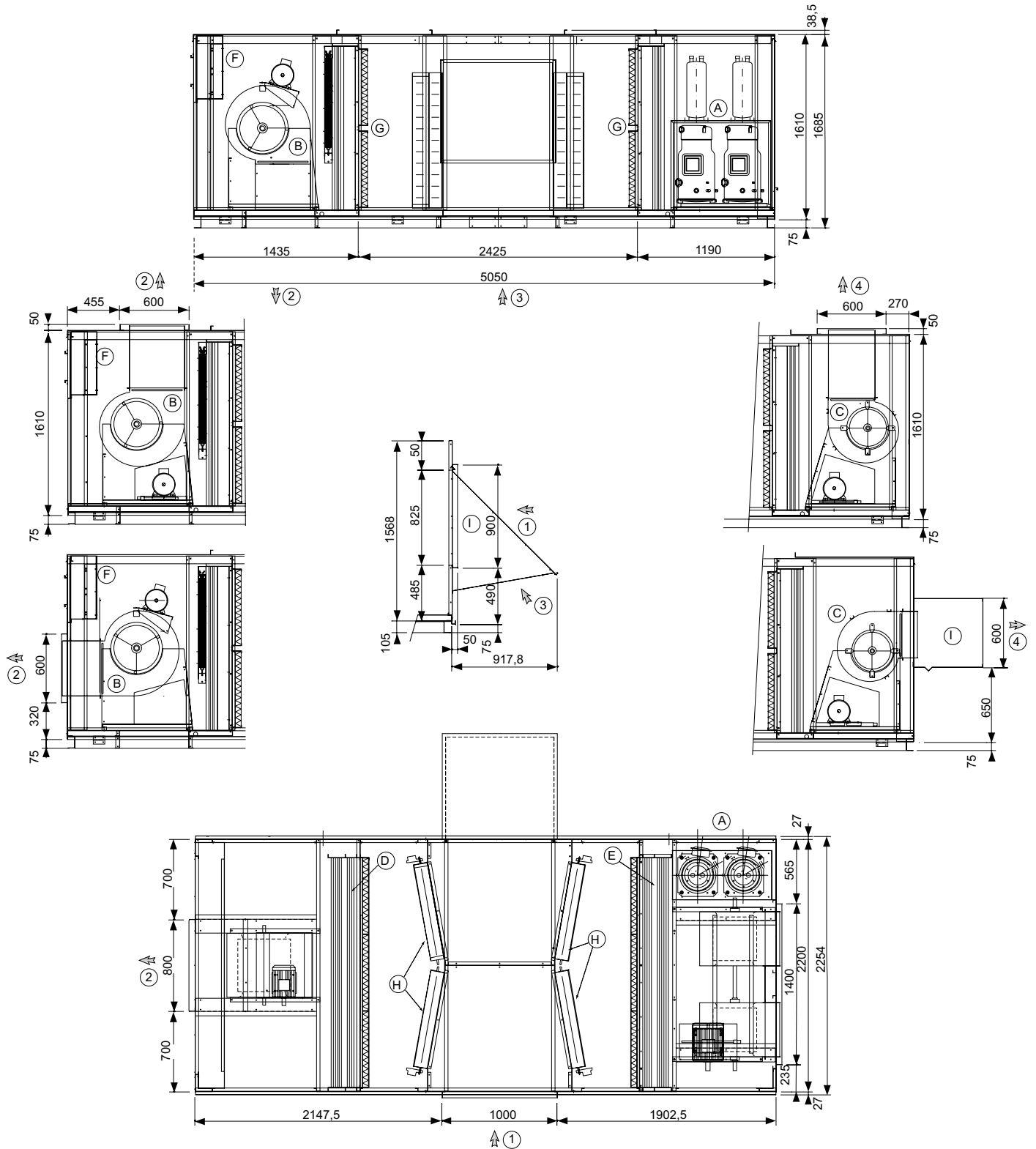

A	Compressor	1	Return air
B	Supply fan	2	Supply air
C	Exhaust fan	3	Fresh air
D	Evaporator coil	4	Exhaust air
E	Condenser coil	5	Flue outlet
F	Control box	6	Power entry
G	Filter	7	Gas entry
H	Damper	8	Condensate drain
I	Air hood		

FXK = Heat recovery unit

FXK **110/140/170**

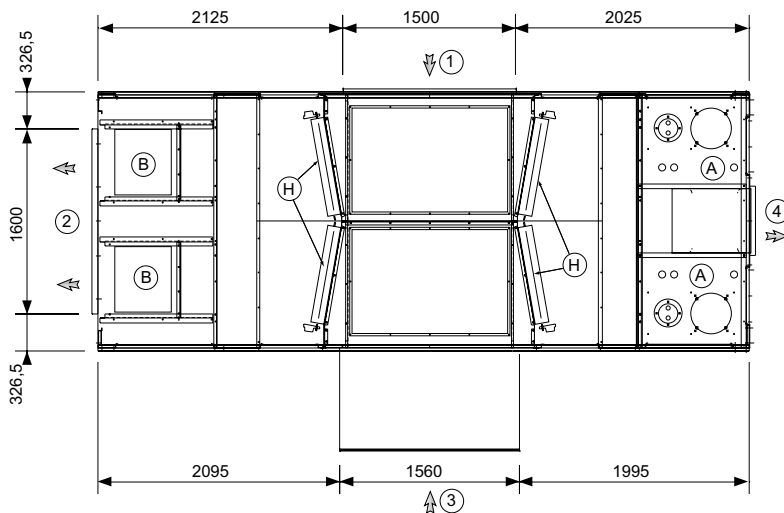
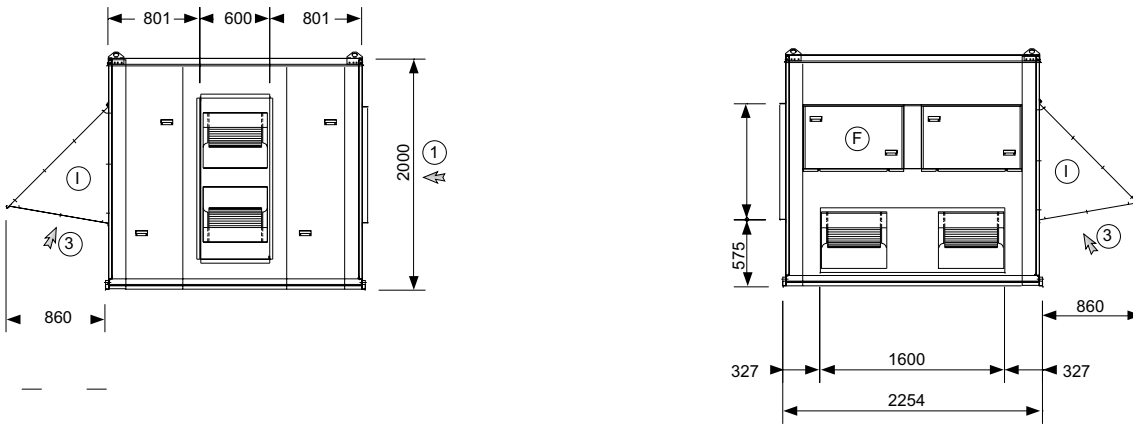
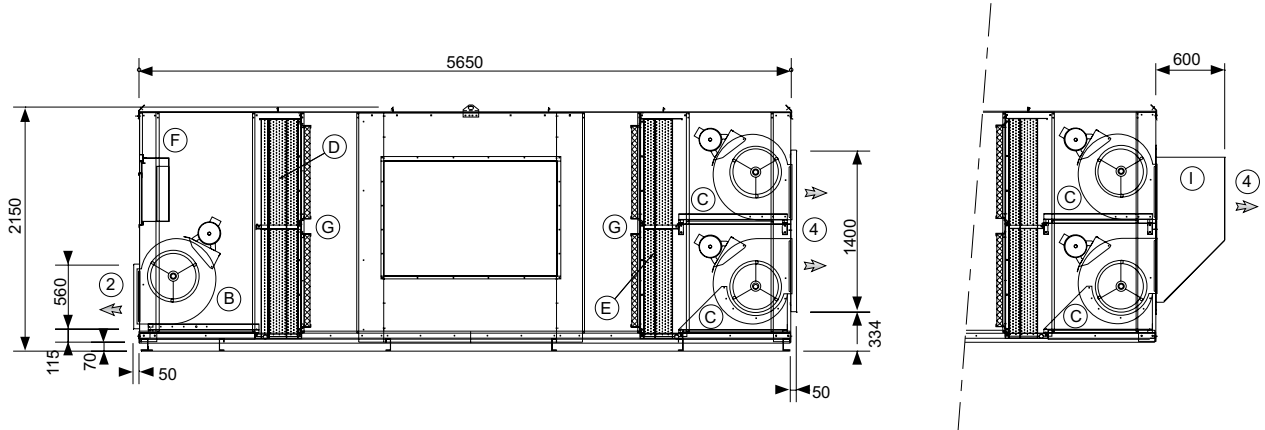

A	Compressor	1	Return air
B	Supply fan	2	Supply air
C	Exhaust fan	3	Fresh air
D	Evaporator coil	4	Exhaust air
E	Condenser coil	5	Flue outlet
F	Control box	6	Power entry
G	Filter	7	Gas entry
H	Damper	8	Condensate drain
I	Air hood		

FXK = Heat recovery unit

FXK **025 -> 170**

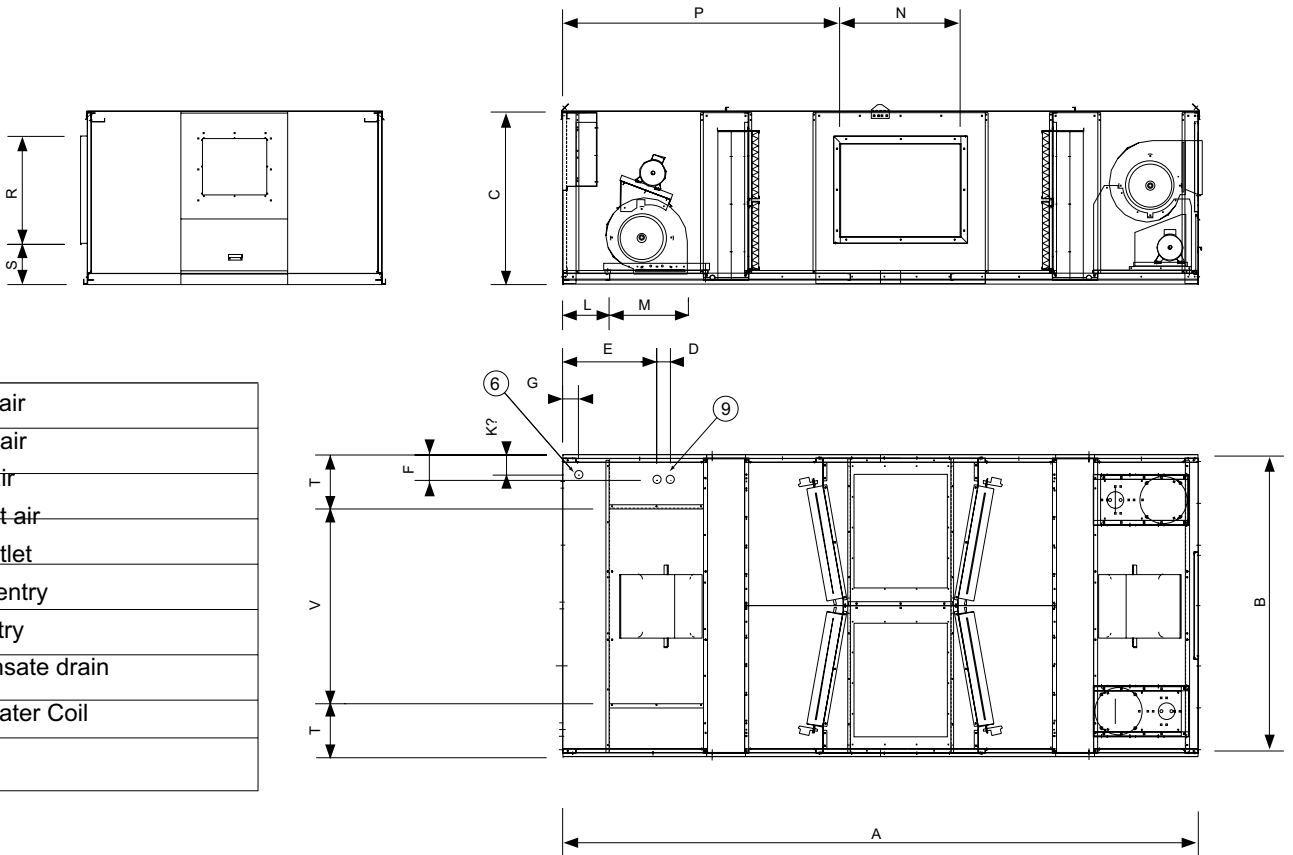

1	Return air
2	Supply air
3	Fresh air
4	Exhaust air
5	Flue outlet
6	Power entry
7	Gas entry
8	Condensate drain
9	Heat Water Coil

SIZE	Weight kg	A mm	B mm	C mm	D mm	E mm	F mm	G mm	K mm
25	950	3970	1610	940	75	320	145	120	145
30	980	3970	1610	940	75	320	145	120	145
35	1400	4750	2254	1290	100	700	180	120	145
40	1450	4750	2254	1290	100	700	180	120	145
55	1600	4750	2254	1290	100	700	180	120	145
70	1800	5050	2254	1610	100	550	180	100	130
85	1900	5050	2254	1610	100	550	180	100	130
100	2000	5050	2254	1610	100	550	180	100	130
110	2300	5650	2254	2000	100	550	180	100	130
140	2400	5650	2254	2000	100	550	180	100	130
170	2600	5650	2254	2000	100	550	180	100	130

SIZE	Weight kg	L mm	M mm	N mm	P mm	R mm	S mm	T mm	V mm
25	950	375	450	800	1665	600	240	505	600
30	980	375	450	800	1665	600	240	505	600
35	1400	350	700	1000	2020	800	300	402	1450
40	1450	350	700	1000	2020	800	300	402	1450
55	1600	350	700	1000	2020	800	300	402	1450
70	1800	460	600	1000	2147	900	490	727	800
85	1900	460	600	1000	2147	900	490	727	800
100	2000	460	600	1000	2147	900	490	727	800
110	2300	110	580	1500	2125	1000	575	327	1600
140	2400	110	580	1500	2125	1000	575	327	1600
170	2600	110	580	1500	2125	1000	575	327	1600

OPTION WEIGHT (STANDARD)



Tabella 10.1

BASE	85	100	120	150	170	200	230
Base Unit FCM	934	1009	1085	1367	1430	1650	1950
Base Unit FHM	949	1024	1100	1397	1460	1680	1980
Base Unit FGM (S)	1041	1116	1192	1608	1671	1914	2214
Base Unit FGM (H)	1111	1186	1262	1631	1694	1954	2254
Base Unit FDM (S)	1056	1131	1207	1638	1701	1944	2244
Base Unit FDM (H)	1126	1201	1277	1661	1724	1984	2284
Air flow configuration							
Downflow return, horizontal supply	23	23	23	30	30	41	41
Horizontal return, horizontal supply	20	20	20	27	27	37	37
Horizontal return, downflow supply	5	5	5	7	7	9	9
Horizontal return, upflow supply	63	63	63	83	83	113	113
Upflow return, upflow supply	57	57	57	76	76	103	103
Fresh air options							
0-25% manual fresh air hood	12	12	12	18	18	20	20
Economiser sensible + hood	57	57	57	75	75	102	102
Exhaust air options							
Gravity exhaust damper for downflow return	14	14	14	19	19	21	21
Power exhaust fan axial + gravity exhaust damper downflow return	41	41	41	63	63	67	67
Return roofcurb vertical	499	499	499	572	572	729	729
Return roofcurb horizontal	474	474	474	557	557	711	711
Energy recovery module 10000m3/h	612	612	612	612	612	612	612
Energy recovery module 20000m3/h	840	840	840	840	840	840	840
Energy recovery module 30000m3/h	900	900	900	900	900	900	900
Energy recovery module 40000m3/h	1214	1214	1214	1214	1214	1214	1214
Filtration option							
G 4 metallic frame, washable filter	6	6	6	11	11	19	19
F7 Filters / G4 Prefilters	36	36	36	44	44	61	61
G4 Refilable filters	6	6	6	11	11	19	19
UV light	4	4	4	8	8	8	8
Refrigeration option							
Low noise LONO	2	2	2	2	2	2	2
Low ambient Kit (down 0°C)	4	4	4	8	8	8	8
Drive kits Standard Units							
K1	-2	-24	-24	-16	-30	-7	-40
K2	0	-22	-22	-7	-22	-11	-45
K3	0	-23	-23	0	-14	0	-34
K4	8	-14	-14	-1	-15	33	-1
K5	7	-15	-15	13	-1	32	-1
K6	38	15	15	12	-3	64	31
K7	21	-1	-1	6	-9	34	0
K8	60	38	38	40	26	1	-33
K9	-3	-25	-25	42	27	65	32
K10	22	-1	-1	-2	-16	79	45
K11	37	15	15	14	0	98	64
K12	37	15	15	72	58	66	32
K13	8	-14	-14	42	28	97	64
K14	22	0	0	74	59		
K15	60	38	38	111	97		
K16	38	16	16	74	60		
K17	92	70	70				
K18	32	9	9				
Drive kits Gas S & H Units							
K1	0	-5	-19	-7	-42	-44	-76
K2	0	-5	-20	0	-35	-33	-65
K3	5	0	-15	35	0	0	-32
K4	13	8	-7	39	4	-1	-33
K5	13	8	-7	71	36	31	-1
K6	19	14	0	85	50	65	33
K7	20	15	0	36	1	50	18
K8	48	43	28	67	32	1	-32
K9	20	15	0	85	50	32	0
K10	52	46	32	99	64	46	14
K11	84	78	64			64	32
K12	80	75	60				
K13	49	43	29				
Heating options versus BCK or BGK							
Electric heater (Standard heat) 2 steps	47	47	47	57	57	78	78
Electric heater (Medium heat) Modulating	64	64	64	78	78	103	103
Electric heater (High heat) Modulating	78	78	78	103	103	143	143
Hot water coil (Standard heat)	34	34	34	52	52	63	63
Hot water coil (High heat)	62	62	62	96	96	116	116
Electric and safety options							
Air sock control	1,5	1,5	1,5	1,5	1,5	1,5	1,5
Other Options							
Non Adjustable non assembled roofcurb	94	94	94	108	108	128	128
Adjustable assembled roofcurb	197	197	197	229	229	272	272
Multi direction horizontal/flow curb	237	237	237	332	332	395	395
Transition roofcurb	123	123	123	145	145	173	173
Refurbishment roofcurb	ND	ND	ND	ND	ND	ND	ND

Tabella 10.2

BASE	85	100	120	150	170	200	230
Base Unit FCM	1378	1453	1530	1957	2020	2420	2720
Base Unit FCM	1398	1468	1545	1987	2050	2450	2750
Base Unit FGM (S)	1485	1560	1637	2198	2261	2684	2984
Base Unit FGM (H)	1555	1630	1707	2221	2284	2724	3024
Base Unit FDM (S)	1500	1575	1652	2228	2291	2714	3014
Base Unit FDM (H)	1570	1645	1722	2251	2314	2754	3054
Air flow configuration							
Downflown return, horizontal supply	20	20	20	27	27	36	36
Horizontal return, horizontal supply	28	28	28	37	37	50	50
Horizontal return, downflow supply	15	15	15	19	19	26	26
Horizontal return, upflow supply	118	118	118	156	156	210	210
Upflow return, upflow supply	126	126	126	167	167	223	223
Fresh air options							
0-25% manual fresh air hood	35	35	35	52	52	58	58
Economiser sensible + hood	100	100	100	133	133	179	179
Exhaust air options							
Gravity exhaust damper for downflow return	33	33	33	48	48	53	53
Power exhaust fan axial + gravity exhaust damper downflow return	60	60	60	92	92	99	99



www.lennox europe.com

BELGIUM, LUXEMBOURG
www.lennoxbelgium.com

CZECH REPUBLIC
www.lennox.cz

FRANCE
www.lennoxfrance.com

GERMANY
www.lennoxdeutschland.com

GREAT BRITAIN
www.lennoxuk.com

NETHERLANDS
www.lennoxnederland.com

POLAND
www.lennoxpolska.com

PORTUGAL
www.lennoxportugal.com

RUSSIA
www.lennoxrussia.com

SLOVAKIA
www.lennoxdistribution.com

SPAIN
www.lennoxspain.com

UKRAINE
www.lennoxrussia.com

OTHER COUNTRIES
www.lennoxdistribution.com

Due to Lennox's ongoing commitment to quality, the Specifications, Ratings and Dimensions are subject to change without notice and without incurring liability.

Improper installation, adjustment, alteration, service or maintenance can cause property damage or personal injury.

Installation and service must be performed by a qualified installer and servicing agency.



FLEXY II-AGU-0607-E